

X1TM

TECHNICAL MANUAL



X1TM

**48v DC ROTOR MATCHING SYSTEM
TECHNICAL MANUAL**

P · 800.543.6618

F · 603.298.8404

info@procutusa.com

www.procutusa.com

9	Limited Warranty	33	Machine Care
10-11	Lathe Overview / Components	34	Troubleshooting / Assuring a Smooth Finish
12	Brake Lathe Specifications	36	Machining Mode from Home Screen
13	List of Standard Accessories	37	Set-up Mode
14	Acceptance from Carrier	38	Statistics Mode
14-18	Safety Information	39	Adjustment for 50-1650 Slide Plate
19	Operations Procedures	40	Lateral Run-out Adjustment / Calibration
20/21	Vehicle Preparation	42	Adapters
22	Lathe Preparation	44	Diagrams
23	Helpful Hints for Rotor Cutting	54	Maintenance Schedule
24-32	Machining Rotors		



***NOTE:** When service or replacement parts are required, please contact your local Pro-Cut Representative through either the SuperTech app or through our website: www.procutusa.com

OUR MISSION

Pro-Cut International is dedicated to providing our customers with the most advanced, precise, and profitable tools for brake repair. We have worked with, learned from and solved problems for people at all levels of the brake repair business - from the largest auto manufacturers and national service chains to one-bay, one-man operations. It is a business our entire staff lives, eats, and breathes. We welcome you to our table and look forward to working with you to improve your brake service business.

CONGRATULATIONS!

You have just purchased what we feel is the finest on-car brake lathe in the world. Your Pro-Cut X1 is a high quality, precision engineered product designed to give you years of trouble free service. To familiarize yourself with all its features, please take the time to read this owner's manual carefully and store this manual in a safe place for future reference.

Our job is not done until you feel your technician team is trained properly and received all the information needed to operate the X1 efficiently, accurately, and above all, SAFELY.

Your warranty will begin once you sign off that you are happy with the training.

For Records and Information:

DATE TRAINED _____ PRO-CUT REP NAME _____

SERIAL No. _____ REP. CONTACT No. _____

FOUND ON TOP OF LATHE

Limited Warranty

This warranty extends to the original owner of the equipment. Pro-Cut International warrants this equipment against defects in materials or workmanship as follows.

Labor

For the period of two (2) years from the original date of purchase, if we determine that the equipment is defective subject to the limitations of this warranty, we will replace it at no charge for labor. Pro-Cut International warrants any such work done against defects in materials or workmanship for the remaining portion of the original warranty period.

Parts

For the period of two (2) years from the original date of purchase, we will supply, at no charge, new or rebuilt replacement parts in exchange for parts we determine are defective subject to the limitations of this warranty. Pro-Cut International warrants any such replacement parts against defects in materials or workmanship for the remaining portion of the original warranty period.

What Your Warranty Does Not Cover

This warranty does not apply to damage due directly to misuse, abuse, negligence or lack of maintenance.

Lathe Overview

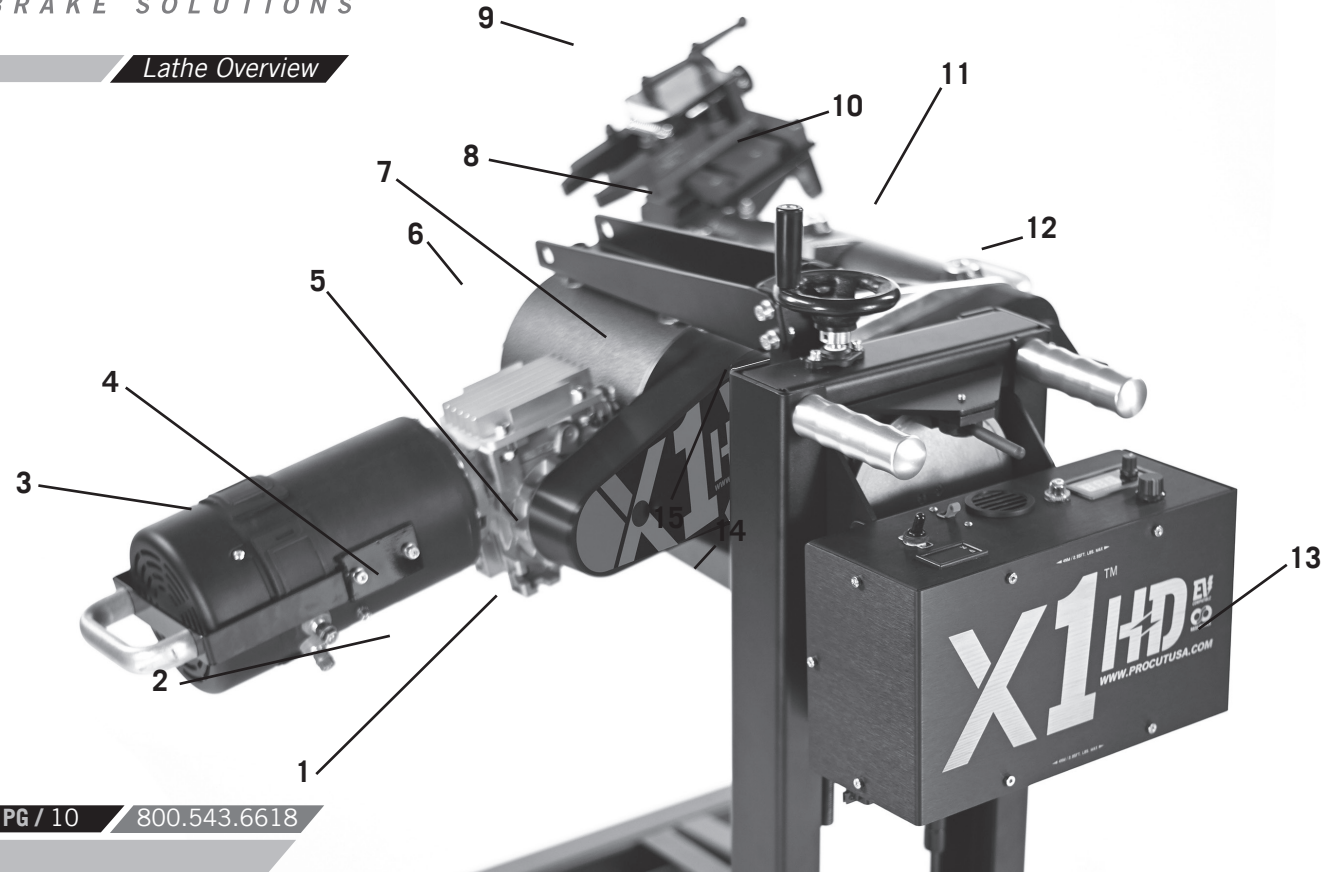

COMPONENTS

- | | | | |
|----|----------------------------|-----|------------------------|
| 1. | Compensation Adjust Button | 9. | Cutting Head |
| 2. | Spindle Speed Select Knob | 10. | Microswitch |
| 3. | 48v DC Motor | 11. | Disc Lock Lever |
| 4. | Emergency Stop | 12. | Feed Clutch (Obscured) |
| 5. | Spindle Start/Stop | 13. | DC Power Supply |
| 6. | Adjustment Solenoid | 14. | Chip Tray |
| 7. | Belt Cover | 15. | Draw Bar Knob |
| 8. | LED Task Lamp | | |

SPECIFICATIONS

- 748W: 125VAC w/ cord 50-1612 or 250VAC w/ cord 50-1614
- Maximum rotor diameter 17.10" [434mm]
- Maximum width of friction surface 4.00" [101mm]
- Maximum thickness 2.00" [50.8mm]
- Variable Spindle Speed 40-100% Speed Adjustment
- Feed per Spindle Revolution: (.005")
- Motor: 48VDC, 1 hp continuous, 2 hp peak power
- Lathe Weight: 110 lbs. [50 kg]
- Lathe Shipping Weight: 200 lbs. [91 kg]
- Trolley Net Weight: 75 lbs. [34 kg]
- Trolley Shipping Weight: 90 lbs. [41 kg]

STANDARD ACCESSORIES INCLUDED WITH THE X1 BENCH LATHE



50-752



50-660



50-179



50-885



50-778



37-034



50-046



30-791



50-703



50-744



37-740



50-376



50-773



37-1900



50-729

- 1 50-752 Lathe Cover
- 1 50-660 Tool Kit
- 1 50-179 Lug Nut Kit
- 1 50-885 Owners Manual
- 2 37-034 Caliper S-Hooks
- 1 50-046 Nose Cone Extension
- 1 30-791 Spacer Ring
- 1 50-703 Chip Deflector
- 1 50-778 Cutting Tips
- 1 50-744 Large Chip Deflector
- 1 37-740 T-8 Flag Wrench
- 1 50-376 Way Oil
- 1 50-754 Chip Deflector
- 1 37-1900 Safety Glasses
- 1 50-729 Brake Spec Guide

***IMAGES NOT TO SCALE**

ACCEPTANCE FROM TRANSPORTATION CARRIER

Carefully inspect all items received in this shipment. If there is damage or evidence of mishandling in transit, determine the extent of damage and notify the transit company as well as Pro-Cut or your local Pro-Cut rep immediately. Although we are not responsible for damage incurred in transit, we will assist in the preparation and filing of claims.

SAFETY INFORMATION

*This manual has been prepared for the operator and those responsible for the maintenance of the brake lathe. Its purpose, aside from proper maintenance and operations, is to promote safety through the use of accepted practice. **READ AND UNDERSTAND THE SAFETY AND OPERATING INSTRUCTIONS COMPLETELY BEFORE OPERATING THE MACHINE.***

In order to obtain maximum life expectancy and efficiency from your brake lathe; follow the operating instructions and maintenance manual carefully. The specifications put forth in this manual were in effect at the time of publication. However, owing to Pro-Cut's policy of continuous improvement, changes to the specifications may be made at any time without obligation on the part of Pro-Cut International, LLC.

IMPORTANT UL SAFETY INSTRUCTIONS

When using your garage equipment, basic safety precautions should always be followed, including the following:

- 1. Read all instructions.*
- 2. Care must be taken as burns can occur from touching hot parts.*
- 3. Do not operate equipment with a damaged cord or if the equipment has been dropped or damaged - until it has been examined by a qualified service person.*
- 4. Do not let a cord hang over the edge of the table, bench, or counter or come in contact with hot manifolds or moving fan blades.*
- 5. If an extension cord is necessary, a cord with a current rating equal to or more than that of the equipment should be used. Cords rated for less current than the equipment may overheat. Care should be taken to arrange the cord so that it will not be tripped over or pulled.*
- 6. Always unplug equipment from electrical outlet when not in use. Never use the cord to pull the plug from the outlet. Grasp plug and pull to disconnect.*
- 7. Let equipment cool completely before putting away. Loop cord loosely around equipment when storing.*

IMPORTANT UL SAFETY INSTRUCTIONS (continued)

8. To reduce the risk of fire, do not operate equipment in the vicinity of open containers of flammable liquids (gasoline).
9. Adequate ventilation should be provided when working on operating internal combustion engines.
10. Keep hair, loose clothing, fingers, and all parts of body away from moving parts.
11. To reduce the risk of electric shock, do not use on wet surfaces or expose to rain.
12. Use only as described in this manual. Use only manufacturer's recommended attachments.
13. ALWAYS WEAR SAFETY GLASSES. Everyday eyeglasses only have impact resistant lenses, they are not safety glasses.
14. To reduce the risk of injury, close supervision is necessary when this product will be used around children. (Pertains to cabinets only.)
15. To reduce the risk of injury, never overload the drawers or shelves. Refer to loading instructions.
16. To reduce the risk of electric shock or fire, never overload receptacles. Refer to markings for the proper load on receptacles.

SAVE THESE INSTRUCTIONS

SAFETY INSTRUCTIONS

1. **Read, understand and follow the safety and operating instructions found in this manual.** Know the limitation and hazards associated with operating the machine.
2. **SPECIAL PRECAUTIONS:** The Pro-Cut X1 brake lathe was designed to machine the portions of the brake disc that come in contact with the friction material. When used according to the instructions herein, this lathe will perform satisfactorily within the work piece size range designed for this model. During the machining operation, the work piece rotates. Be especially cautious of rotating spokes and mounted accessories. During machining, material removal may cause a sharp edge to be generated, where a chamfer or radius previously existed. Use care in handling machined parts.
3. **GROUNDING THE MACHINE:** In the event of a malfunction or breakdown, grounding provides a path of least resistance for electric current to reduce the risk of electric shock. The lathe is equipped with an electric cord having an equipment-grounding conductor and a grounding plug. The plug must be plugged into a match outlet that is properly installed and grounded in accordance with all local codes and ordinances. Do not modify the plug provided. If the plug will not fit the outlet, have the proper outlet installed by a qualified electrician. If repair or replacement of the electric cord or plug is necessary, do not connect the to a live outlet until repairs are performed. Check with a qualified electrician or service personal if the grounding instructions are not completely understood, or if in doubt as to whether the lathe is properly grounded.
4. **EXPLOSION RISK:** This machine generates internal sparks. Do not use at less than 18" [0.46m] above grade level, and never use below grade level. Work area should be well ventilated and free of explosive fumes.

SAFETY INSTRUCTIONS (continued)

5. **USE PROPER EXTENSION CORD:** Use only 3-wire extension cords that have 3-prong grounding plugs and 3-pole receptacles that accept the lathe's plug. Repair or replace damaged or worn cord immediately. Make sure your extension cord is in good condition. When using an extension cord, be sure to use one that is 15' or less and 14ga or heavier (i.e. 12ga).
6. **EYE SAFETY:** Wear an approved safety face shield, goggles, or safety glasses. (Ordinary eyeglasses are not safety glasses and do not provide the degree of protection necessary.)
7. **RESPIRATORY SAFETY:** If the operation or area is dusty a face or dust mask should be used.
8. **PERSONAL PROTECTION:** Before operating the machine, remove tie, rings, watches and other jewelry, and roll up sleeves above the elbow. Remove all outer loose clothing and confine long hair. Protective type footwear must be worn. Hearing protectors must be used where noise exceeds the level of exposure allowed in Section 1910.95 of the OSHA Regulations. **DO NOT WEAR GLOVES.**
9. **DO NOT USE LATHE IN DANGEROUS ENVIRONMENT:** Don't use the lathe in damp or wet locations, or expose the lathe to rain. Keep the work area well lighted.
10. **DO NOT OVERREACH:** Maintain a balanced stance and keep your body under control at all times.

SAFETY INSTRUCTIONS (continued)

11. **HAND SAFETY:** Keep hands away from moving parts when the machine is under power. Never clear chips or debris when the machine is under power and never use your hands to clear the chips. Never use compressed air to clean machine; use only a soft bristle brush or vacuum cleaner.
12. **MACHINING PREPARATION:** Tighten all appropriate locks before operating the lathe. Be sure work piece is secured. Remove adjusting keys and wrenches. Be sure to check to see that all adjusting wrenches are removed from the lathe before turning the machine on.
13. **CHECK DAMAGED PARTS:** Before further use of the lathe, a guard or other part that is damaged should be carefully checked to determine if it will operate properly and perform its intended function. Check for alignment of moving parts, binding of moving parts, breakage of parts, mounting, & any other conditions that may affect the lathe's operation. A guard or other part that is damaged should be properly repaired or replaced.
14. **MAINTAIN TOOLS WITH CARE:** Keep tools sharp and clean for best and safest performance. Follow instructions for lubricating and changing accessories.
15. **NEVER STAND ON LATHE:** Serious injury could occur if the lathe is tipped or if the cutting tool is unintentionally contacted.

SAFETY INSTRUCTIONS

16. **MACHINE CAPACITY:** Do not attempt to use the machine for other than car or truck discs, or for operations for which the machine was not intended.
17. **CARELESS ACTS:** Give the work you are doing your undivided attention!
18. **Disconnect Electrical Power before performing any service, maintenance, or changing of accessories or adapters.**
19. **JOB COMPLETION:** If the operator leaves the machine area for any reason, the machine should be turned off, and the spindle brought to a complete stop before the operator departs. In addition if the operation is complete, the operator should clean the machine and work area. NEVER CLEAN THE MACHINE WITH THE POWER ON.
20. **REPLACEMENT PARTS:** Use only Pro-Cut replacement parts and accessories, risk of injury may result in accessories other than those recommended are used.
21. **MISUSE:** Do not use the machine for other than its intended use. If used for other purposes, Pro-Cut International, LLC, disclaims any expressed or implied warranty, and holds itself harmless for any injury or loss that may result.

X1 MULTI-SPEED BRAKE LATHE TECH TIPS

The X1 Multi-Speed Lathe has a feed rate of .005" [.127mm] per revolution and a variable spindle speed.

Choose spindle speed based on the size of the work piece, slower for larger diameter brake rotors/discs.

75-80% spindle speed may also give a better surface finish. For some trucks with speed-sensitive locking axles, you may need to reduce the speed to 40% to stay below lock-up rpm.

No guarantee can be made for inserts not purchased from Pro-Cut, as insert corner radius, relief angle, material composition and edge preparation can have a strong effect on cutting quality, insert lift, and tendency of the work piece to vibrate. Always use Genuine Pro-Cut 50-778 inserts for best results.

The maximum recommended depth of cut is 0.015" / 0.38mm per insert.

VEHICLE PREPARATION

Before lifting the vehicle, the front wheels should be straight and the parking brake should be off, with the transmission in neutral, and the traction control turned off.



Download the APP for Training, Videos, Rep Contact, Diagrams and more!

1. Raise the vehicle according to the lift manufacturer's instructions. Raise until the wheel hub is about belt level.
2. Check wheel bearings for damage or excessive play. If this or any other wheel service is required, it should be performed before match-machining the rotors as loose or damaged bearings will keep the lathe from doing the most accurate job possible.
3. Remove the wheels. Remove the brake calipers and suspend them out of the way of moving parts such as half shafts and CV joints using the yellow S-hooks provided (37-034). Be sure to remove all wheels that may turn when the lathe is turned on.
4. Use Pro-Cut part number 37-996 or 37-997 wheel hub cleaning kit, or other suitable wheel hub cleaning tool to remove rust or debris. Clean all material from the mounting area.
5. The rotor on the side of the vehicle that is not to be machined should be marked and removed if it is free on the hub or secured with at least 2 lug nuts. Match marking the rotors to the hub is very important.
6. Use a micrometer to measure rotor thickness and determine how much material may be removed from the rotor by comparing to brake spec. Visually inspect for deep rust or grooves. This inspection will help determine the depth of the cut.

NOTE: Remember to index mark rotors before removing them so you can be sure they are returned to the same positions on the hub.

It is important to start on the proper side. The Pro-Cut mounts directly to the hub of the vehicle. With the lathe right-side up (FIG:1) the cutting head is to the right of the hub as you face the vehicle wheel well. When machining a rotor, the cutting head is most often positioned where the caliper rides. On a vehicle where the calipers ride in front of the hub, always start on the passenger side. If the caliper rides to the rear of the hub, begin on the driver's side.

When you flip the lathe to machine the opposite side of the vehicle (FIG:2), no inboard / outboard cutting head adjustments are required since they were made in the upright position.

***NOTE: Always rotate the motor over, to avoid cord wrapping/tangling.**

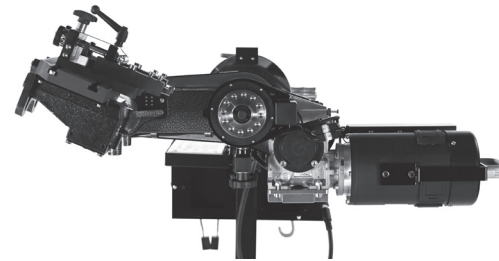

FIG:1 | Lathe in upright position. Note that adjustments to cutting head are made in this position.

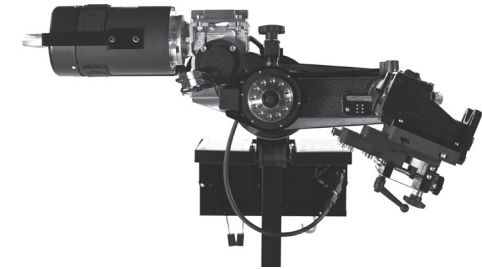

FIG:2 | Lathe in upside-down position. You will need to flip the lathe over into this position to machine one side of the vehicle if there is a dust shield, or other interference behind the rotor.

NOTE

The Pro-Cut X1 machines both front and rear rotors. The lathe's set-up steps do not change at all in the rear of the vehicle.

LATHE PREPARATION CHECK CUTTING TIPS

Before mounting the lathe, check the cutting tips and make sure they are ready for use. The cutting tips are one of the most critical components of the machine. It is vital that they are Pro-Cut brand tips in good condition and properly mounted. Each cutting tip has three corners which may be used. The correctly installed tip is wider on the top and has a groove, or dots, facing up.

You should get at least 10 cuts per corner. However, tip life is affected by variables such as rust or ridges. In order to determine when to rotate tips, monitor rotor finish. If the rotor finish begins to look inconsistent, or feels rough to the touch, tips should be rotated. Tips that are chipped or cracked should never be used.

Be sure that the tip pocket is clean before positioning the tip. Any foreign material pinched under the tip will cause problems.

CHECK CUTTING TIPS (Continued)

NOTE: Use only Pro-Cut Cutting Tips (50-742 or 50-778). Although other tips may fit the machine, only Pro-Cut tips have been specifically engineered in tandem with the Pro-Cut lathe. Using a non-Pro-Cut tip may compromise lathe performance and result in poor surface finish.



PREMIUM PLUS CUTTING HEAD SHOWN

When the tip is mounted correctly, the chip breaker and dots face up.

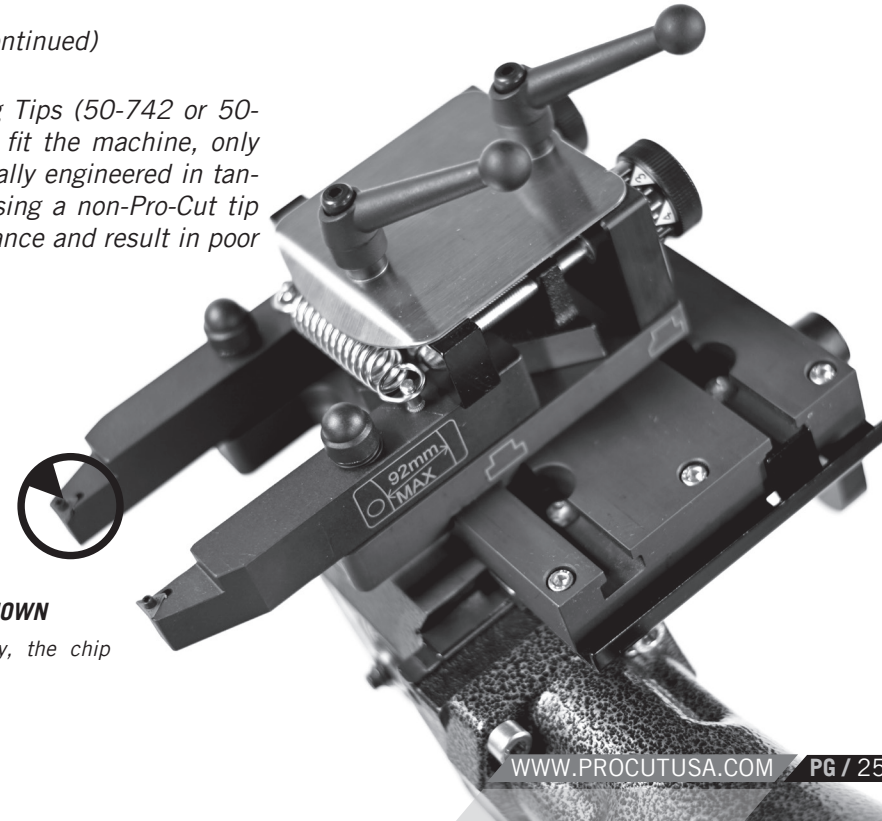

MACHINING ROTORS In just 3 steps in about 7-9 minutes, any tech can perform top-quality brake work.



If the three steps are followed properly on each brake job, the Pro-Cut X1 will operate accurately and efficiently. Scan the QR Codes for in-depth videos detailing the steps of the 3C's!

C1 / CONNECT: Connect the adapter to the vehicle and the lathe to the adapter.

The First step is to choose the proper adapter. See the adapter search on the Pro-Cut website or SuperTech app, or Adapter Search app to find correct adapter for your vehicle. Be certain to also note the correct position number as well for proper fit.



Once you've selected the correct size adapter, place it over the studs or threaded holes (European vehicles) in the correct position indicated by the adapter guide. When possible, use the nuts provided 50-179 lug nut/stud kit. Tighten nuts with an open box end wrench or a torque wrench in a star pattern. Do not use high torque impact guns to mount adapters. Nuts should be tightened to 25-30 ft. lbs. Excess torque may damage the adapter.

Some trucks require the use of a spacer (30-791) which is provided in the lathe package. If the adapter doesn't fit flush and square, use the spacer.

MACHINING ROTORS CONTINUED

C1 / CONNECT (continued)

Mount the Lathe to the Adapter

Move the cutting head out with the clutch so that the tips will not strike the rotor as you mount the lathe.

Next, roll the machine into place and match it up with the adapter. Note that the trolley moves up and down to accommodate different heights. The small dowel pin on the face of the adapter will fit into any of the 12 holes on the run-out adjustment flange. Turn the draw bar knob to thread into the adapter securely connecting the lathe to the vehicle.

NOTE: It is very important that the machine be mounted smoothly on the adapter without prying or forcing. Take the time to align the machine properly in order to avoid damage to the run-out adjustment flange. The large draw bar knob will spin on very easily when the machine is properly aligned, much like installing an oil filter. Tighten it by hand but firmly enough to move the rotor.

Position the Cutting Head for Machining

Loosen the trolley lock lever so that the machine is free to rotate. Rotate the machine so that the cutting head is in a position where there is clearance to make the cut. Be sure to check the back side of the rotor for obstacles. Make sure there will be clearance for the chip deflector as well. **Lock the trolley lever so the machine will not rotate when the motor is started.** Loosen rear lock on cutting head and slide laterally until tool arms are evenly spaced on either side of the rotor/disc, but not over the disc. Lock the rear lock lever. Slide stop cam along slide plate rail until cam is in position to engage stop microswitch when cut is complete.

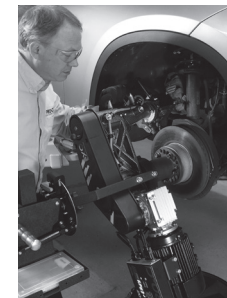

Step 2: Technician mounts the lathe to the adapter

SECURING THE CUTTING HEAD

Vibration is the root cause of most surface finish problems. Be sure the cutting head is securely locked in place. Tight connections here reduce the chance of vibration.

WARNING

DO NOT USE IMPACT GUNS TO ATTACH THESE ADAPTERS! Twenty to thirty ft.-lbs. applied by hand is plenty to secure the adapter to the vehicle. Excess torque applied with an impact wrench may damage the adapters. **Warranty does not cover this misuse.**

C2 / COMPENSATE: COMPENSATE FOR LATERAL Run-out

You must adjust for lateral run-out to eliminate wobble (run-out) from the lathe before machining. This procedure ensures the resulting machined rotor will have minimal run-out after cutting. The PFM X1 Rotor Matching System has been calibrated to reduce run-out to less than 0.001" [25.4 micron] or less as measured on the rotor face.

COMPENSATE FOR Run-out

The PFM X1 Rotor Matching System compensates for run-out automatically. With the machine mounted securely to the adapter and all potential interfering items clear of the rotating assemblies, press the motor on switch. With the machine running smoothly, press and hold the ADJ button on the DRO computer board for 2 seconds. A clicking sound will be heard throughout the adjustment process, which is the adjustment solenoid changing the angle (at the adjustment flange face) until run-out is reduced to within vehicle specification. The lateral movement of the lathe as measured at a 12" / 305mm diameter (6" / 152mm from the center of hub) will be displayed on the Digital Read Out (DRO) screen.

This procedure will usually take between 10 to 45 seconds. Total adjustment time depends on a number of factors including initial run-out and the resistance in the hub and spindle speed selected. Slower spindle speeds will reduce compensation time. Average adjustment time is less than 30 seconds, but may take up to 90 seconds depending on vehicle set-up. When the machine is done adjusting, green lights and a displayed lateral run-out value on the digital display will give feedback on the compensated status of the lathe.

For example, a measurement of 0.0005" [38 micron] could be displayed on the DRO and a green light will be illuminated next to "Matched" on the display.



Detail of the computer box.

C2 / COMPENSATE FOR LATERAL Run-out (Continued)

If the ALERT light is illuminated, the machine is unable to fully adjust for run-out. This difficulty could be due to looseness of fittings, irregular run-out, damage to wheel bearings or other components, or other factors relating to set-up. The best procedure is to loosen the machine from the adapter, check adapter and vehicle setup, rotate the adapter locator pin 180 degrees, and attach the machine again. Make sure that the machine is adequately supported by the trolley. Run the adjustment procedure and the machine should adjust for run-out. If ALERT appears repeatedly, there is most often a problem with the vehicle. You should dismount the machine and check for a damaged wheel bearing or CV joint. Such problems will have to be addressed before match-machining is possible.

If the machine seems to be having excessive difficulty in adjusting for lateral run-out, consult the troubleshooting section on the Supertech app or at www.procutusa.com.

NOTE



DRO computer in READY mode displaying speed.



DRO computer compensated for lateral run-out to 0.0006" and ready to cut.

MACHINING ROTORS

C3 / CUT: MAKE THE CUT

With the motor running, loosen the forward lock lever on the cutting head to allow cutting depth adjustment.

Turn cut-depth knobs counter-clockwise until the tips can clear both sides of the rotor. Crank the cutting head in to 1/4" [6.35mm] from the outer edge of the braking surface of the rotor.

Start with the inside (behind the rotor) tool arm. Turn the depth knob clockwise (tighten) until the tool tip makes full 360 degree contact (complete circle) on the rotor surface. You can listen for the contact. Next move the outside tool arm in until it also does the same.

If there is a large ridge on the outer edge of the rotor, you may remove that by snugging down the tool arm lock lever, depressing the feed clutch and allowing the lathe to cut off the ridge. Now back off the tool arms 5 clicks (counterclockwise) each, and wind the cutting head back in now to 1/8th of an inch from the inside starting point of the cut, or as close as you can get and still be on good rotor surface on both sides. Be careful not to crank the cutting arms into the "hat" of the rotor. **Damage caused by advancing the cutting arm into the hat of the rotor is not covered by warranty.**

When you are at the inside edge of the pad contact surface, you may adjust for depth by turning the depth knobs clockwise the 5 clicks you previously backed off, which should be the original scratch point from the test scratch on the outer edge. If the cutting tips are not touching the rotor then you must turn the knob(s) clockwise until they do - this is your start point to add the depth of cut. Each click of the knob represents cutting tip movement of 0.001" (0.025mm). Cut at least 0.0054" / 0.10mm (or four clicks) on each side with each pass for average size rotors. The maximum depth is 0.015" / 0.38mm per side, per pass.



STEP 4.
Technician sets cut depth.

WARNING

It is extremely important not to touch the hat of the rotor with the outer tool holder. This may damage the tool holder plate. This type of damage is **NOT COVERED BY THE WARRANTY.**

MACHINING ROTORS

C3 / CUT (Continued)

The exceptions to this rule would be extremely large and thick rotors such as on a Medium Duty truck, or very thin solid rotors such as on the rear of a small car. In these applications, the depth rule is reversed and the minimum cut can be reduced to 0.002" / 0.05mm per side per pass, and the maximum cut depth should be limited to 0.005" / 0.13mm per side per pass. Other specialty rotors, such as cross-drilled or slotted, may also require a reduced cut depth. **Note: See our web site for tech-tips on cutting larger and specialty rotors.**

Now that you have adjusted for depth, tighten the forward lock lever (over the tool arms). This lever must be tight to minimize vibration. **For safety, it is advised at this time that you turn the motor off. Place the chip deflector around the rotor and over the cutting tips.** Grooves in the chip deflector will fit snugly over the cutting tip screw heads when installed correctly. There are currently three types of chip deflectors. The first, the 50-703 standard version, is used in most smaller vented rotor applications. The second, the 50-754, has double thick blocks and a lock clip to increase pressure on the rotor. The 50-773 chip deflector works well when the tool arms are retracted. The third, the 50-744, has thicker wire and a stronger spring for larger vented rotors on cars and trucks.



Pictured above is the 50-773, which has double thick blocks and a profile that works best when the tool arms are retracted.

MACHINING ROTORS

C3 / CUT (CONTINUED)

Once cut depth is set, tool arms are locked down, chip deflector is secure, and draw bar tightness is double checked, you may turn the motor back on. Press the feed engagement knob to engage the automatic feed. Provided that you previously set the shut-off cam correctly, the lathe will shut off when the cut is complete. The cut will take two to four minutes depending on the size of the rotor, and the spindle speed selected.

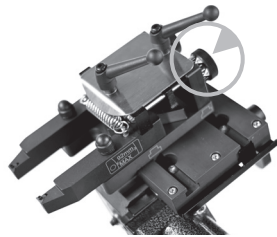

Turn the dials clockwise to advance the cutting tip depth. Each click of the dial indicates .001".



The chip deflector rides over the cutting arms as shown above.

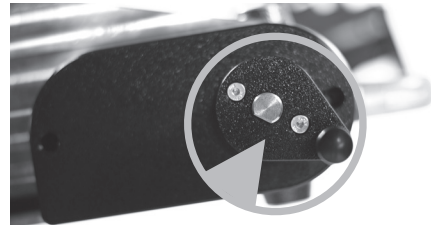

Move the cutting head by turning the clutch knob shown above, clockwise for away from the rotor, counter-clockwise for towards the rotor.

When you are finished cutting, loosen the cutting arm lock lever, and turn the dials counter clockwise so they will clear the larger thickness of the second rotor. Loosen the draw bar knob and remove the lathe from the adapter. Be careful not to bump either the rotor or the wheel with the cutting head as you dismantle the lathe. Take special care not to bump the cutting tips against the rotor.

MACHINING ROTORS

MACHINING THE OPPOSITE SIDE

1. Loosen the trolley disc lock lever and rotate the machine into the upside-down position.
2. The procedure for cutting in the upside-down position is the same, though fewer steps are needed as the lateral position of the cutting head relative to the rotor is already set. The lathe mounts in the same manner. Often, the shut-off switch will still be depressed from the previous cut, so the machine will not turn on until you advance the cutting head slightly. The cutting arms will also still be advanced in from the last cut, so be sure to loosen the forward lock lever and spread the tool arms before feeding the head towards the center of the rotor. Measuring and adjusting for run-out is exactly the same as in the upright position. The entire cutting process is also the same, right down to the chip deflector which mounts in the exact same position.

NOTE

Be sure the auto shut-off is not still engaged from your first cut!

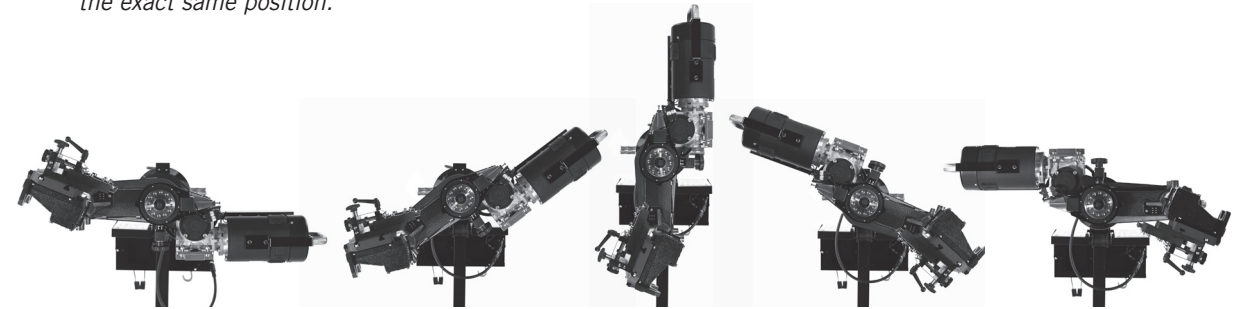

After loosening the trolley handle, always rotate the lathe by the motor to avoid cord wrapping / tangling to machine the opposite side of the vehicle.

MACHINING ROTORS

POST MACHINING BEST PRACTICES

*Before removing the adapter, measure and record the lateral run-out on the rotor. Also measure and record the thickness to ensure that it is above "machine to" specification. You may compare to factory specifications in the Pro-Cut Brake Spec Guide provided, or other reliable certified source. When you have finished your measurements, be sure to clear the hub, caliper bracket, and speed sensors of any brake chips, dust or debris. **Optional:** With the motor running, finish sanding with a 150 grit sandpaper on a sanding block on each side of the rotor for 1 minute will serve to improve the surface roughness average. Excellent surface finishes provide the least amount of initial brake noise and the best customer satisfaction.*

Cleaning the rotor surface after machining to remove all dust and debris is very important in the overall quality of the brake job. Pro-Cut recommends using liberal amounts of warm water with a mild detergent and drying thoroughly with clean towels to be certain all loose material is removed.

MACHINING ROTORS

VEHICLE REASSEMBLY

Be sure to torque all lug nuts to manufacturer's specification with a torque wrench or other calibrated tool. Excess or uneven torque can deflect the rotor and actually induce additional run-out, destroying the accuracy of the rotor matching process.

MAINTENANCE

The Pro-Cut lathe is simple and rugged. With just a few maintenance tips you can ensure a long and profitable life for your machine.

Check cutting tip edges. (Pro Tip: Your phone's 'magnifier' utility is great for this!) If there are chips or dings, turn or replace the tip. Be sure they are right-side up so that the groove and dots are visible. Each tip has three cutting points. When worn out, replace them using a T-8 wrench as the one provided with the tool kit. Although the tips must be securely tightened, do not over-tighten them either. When changing tool tips, clean the threads and put a spot of Vaseline ® (or thick grease) in the bottom of the screw hole before tightening the tool bit screw. The Vaseline / grease will stop chips from accumulating in the hole and rusting in place. If chips do rust in place, they can often be dislodged by poking a needle through the hole.

Clean the slide plate and tool holder plate, taking special care that there are not chips or dirt wedged in the dovetails or under the tool arms. Check the electrical connections and cord for cuts in the insulation or for wear.

WEEKLY MAINTENANCE

Lubricate the dovetail ways with Pro-Cut 50-376 way oil once a week. Also lubricate the drawbar washers for smooth engagement with adapter and faster compensation times.

Check the slide plate for lateral play. Lateral play often causes ridges and machining grooves when a rotor is resurfaced. To check for lateral play, grab the slide plate assembly and try to wiggle it side to side.

For details on how to adjust the slide plate, see page 41, or contact the Pro-Cut service dept at 800-543-6618 option 2, or contact your local rep on the SuperTech app.

TROUBLESHOOTING ASSURING A SMOOTH FINISH

NOTE

The Pro-Cut X1 should provide a smooth surface finish on every cut, free of chatter, tone, or roughness. If your machine leaves a substandard, "chattery" or rough finish, you need to find the problem. The following pages are the common sources of poor surface finish and ways to remedy the problem.

Brake performance is dependent upon rotor surface finish as well as minimizing lateral run-out. The Pro-Cut lathe is designed to give you a superior surface finish on any rotor as long as proper maintenance is followed.

Minimizing vibration during machining is the key to high-quality surface finish. It is critical that all contact points between the rotor and the lathe are secure – specifically, the connections between lathe and adapter; the slide plate and the lathe; the cutting head and the plate; and the tips and the tool holders. Looseness in any of these areas will compromise lathe performance and surface finish.

TROUBLESHOOTING

CHECK CUTTING TIPS

The cutting tips must be right-side up. Dots or ridges face up. The cutting tips should not have chips or dings in the surface of the points. Do not take cuts of less than 5 thousandths of an inch / 0.13mm unless necessary for non-vented, drilled, or rear of dual wheel trucks. Cuts of 5 to 10 thousandths / 0.13-0.25mm per side will provide the best surface finish and the longest tip life for for vented rotors of normal size.

MAKE SURE THE CUTTING HEAD IS SNUG

On each brake job, the technician must center the cutting head. Once the head is centered, it is vital that the technician tighten the cutting head lateral lock lever securely. Failure to do this may result in chatter.

USE THE CHIP DEFLECTOR

The chip deflector included with the lathe is a critical component. The pressure of its pads provides dampening that reduces the chance of vibration while cutting. The chip deflector should be used on every cut to ensure proper finish. New chip deflectors can be purchased directly from Pro-Cut.

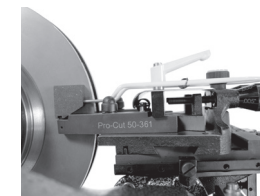

The chip deflector reduces vibration and should be used on **EVERY** cut.

MACHINING MODE FROM HOME SCREEN



SET-UP MODE SPINDLE MOTOR MUST BE OFF



Set-up Mode:

- Long Press > 3 seconds to enter set-up mode.
- Rotate to scroll through options and toggle between choices within an option.
- Short press to select option or drill down to another level.
- Long press to accept changes

Available Options in Order:

- Maintenance Alert Reset
- Unit >Inch/mm
- LRO .001 > Adjust
- Maintenance Alert >On/Off
- Maintenance Interval > up/down
- Reset Lathe >

Statistics Mode:

- Short Press < 3 seconds to enter Statistics mode.
- Rotate right to scroll through options.

Available Statistics:

- LRO Compensations (#rotors machined)
- Life Average Compensation Time
- Last 5 Compensation Time
- DC Motor Hours
- Power Cycle Count
- Current Version/s



Slide Plate Resistance Adjustment

1. Remove the Cutting Head from the Slide Plate.
2. Center the Slide Plate on the Gear Box between the screws that are through the dove tail plate.
3. Locate and loosen the 2 wedge locating screws on the slide plate.
4. Be sure that the runners of the slide plate are clean and free of debris.
5. Grasping the slide plate on the side opposite of the slide rail, wiggle it back and forth at the same time push on the side where the rail is located.
6. Tighten the 2 wedge locating screws.
7. Test the resistance of the slide plate by turning the clutch knob. There should not be any sideward movement or looseness in the slide plate but it should travel smoothly along the ways.
8. Lube the 60° ways with Pro-Cut 50-376 way oil.

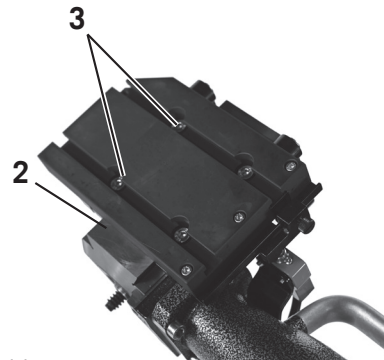

Detail of the 50-1690 Slide Plate

LATERAL Run-out ADJUSTMENT

If the machine is having difficulty adjusting for lateral run-out, first assess the vehicle being serviced. If lateral movement is rough or uneven due to damaged vehicle components, these components must be repaired or replaced before rotors are match-machined. It is also important that the machine be supported by the trolley during adjustment. Vertical position and camber shocks must be in good condition to support the lathe. Worn shocks can impact compensation.

CALIBRATION PROCEDURE

The Pro-Cut PFM X1 Rotor Matching System *is calibrated with an acceptance number from the factory. Normally, this will never need to be changed. Please call Pro-Cut Service Department before attempting calibration procedure to confirm that this is the problem.*

6 8 COMMON ADAPTER PACKAGES

(See Adapter Accessory sheet for complete adapter options)



50-687

4-HOLE ADAPTER

Fits most 4-lug vehicles.



50-688

5-HOLE ADAPTER

Fits most smaller 5-lug vehicles.



50-693

5-LUG ADAPTER - LARGE

Fits larger 5 lug cars and smaller SUVs and trucks such as Toyota Camry, most BMW models, and Chevy Equinox.



50-946

LIGHT DUTY 6 LUG ADAPTER

6 lug adapter fits newer Colorado/Canyon, some Cadillacs, and 6 lug single rear wheel Sprinters.



50-681

TOYOTA SPECIALTY & ALTERNATE TRUCK ADAPTER

Fits most pickups and SUVs including the Toyota Land Cruiser and VW Touareg (does NOT have older common Ford pattern found on the 50-691 adaptor).



50-694

TALL HUB TRUCK ADAPTER

Primarily used to fit the 2003+ Expedition and 2004+F150, this adapter shares patterns with other common trucks that have tall hubs which may interfere with the 50-691 adapter.



50-683

3/4 TON TRUCK ADAPTER/COMMON

Fits most 3/4 ton single wheel trucks front and rear.



50-935

DUAL WHEEL TRUCK ADAPTER

Fits 1-ton Ford, Dodge, and Chevy trucks and vans with dual wheels.

50-2300

ITEM NO.	PART NUMBER	QTY.
1	50-2201	1
2	50-883	1
3	37-2212	1
4	50-2390	1
5	50-2248	1
6	50-2249	1
7	50-2238	2
8	50-2207	1
9	50-2209	1
10	50-1831	1
11	50-2218	1
12	50-565	1
13	50-1845	1
14	37-1805	1
15	37-1845	1
16	36-010	4
17	37-1808	1
18	50-567	1
19	50-2217	1
20	50-2210	2
21	37-156	3
22	35-800	3
23	37-003	7
24	37-454	4
25	37-025	1
26	37-967	4
27	35-320	1
28	35-317	2
29	35-364	4
30	36-173	1
31	35-236	4
32	35-280	6
33	35-281	2
34	35-926	3
35	37-117	1
36	35-251	1
38	50-2282	1
39	50-560	1
40	35-835	2

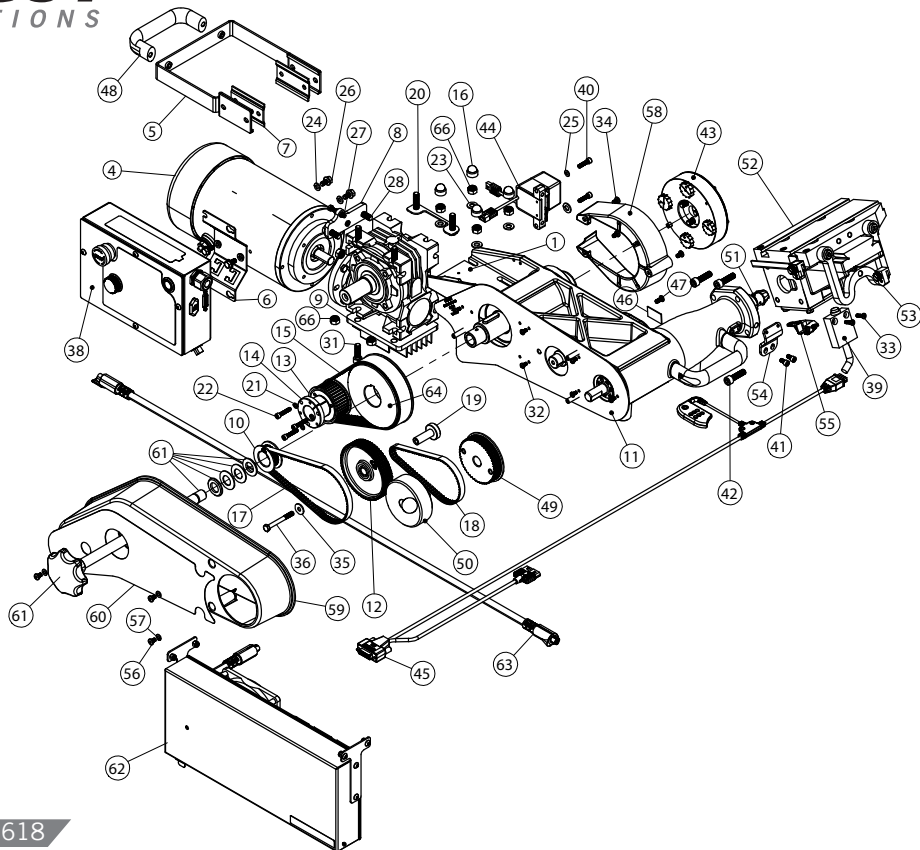

ITEM NO.	PART NUMBER	QTY.
41	35-811	2
42	37-274	4
43	50-2400	1
44	50-1804	1
45	50-2223	1
46	37-2208	1
47	35-278	1
48	37-813	1
49	50-566	1
50	50-570	1
51	50-2220	1
52	50-1690	1
53	50-1824	1
54	50-2214	1
55	50-1142	1
56	35-834	3
57	37-025	3
58	50-2208	1
59	50-2242	1
60	50-881	1
61	50-2239	1
62	50-2370	1
63	50-2381	1
64	50-1857	1
65	37-426	1
66	36-002	10

50-2195

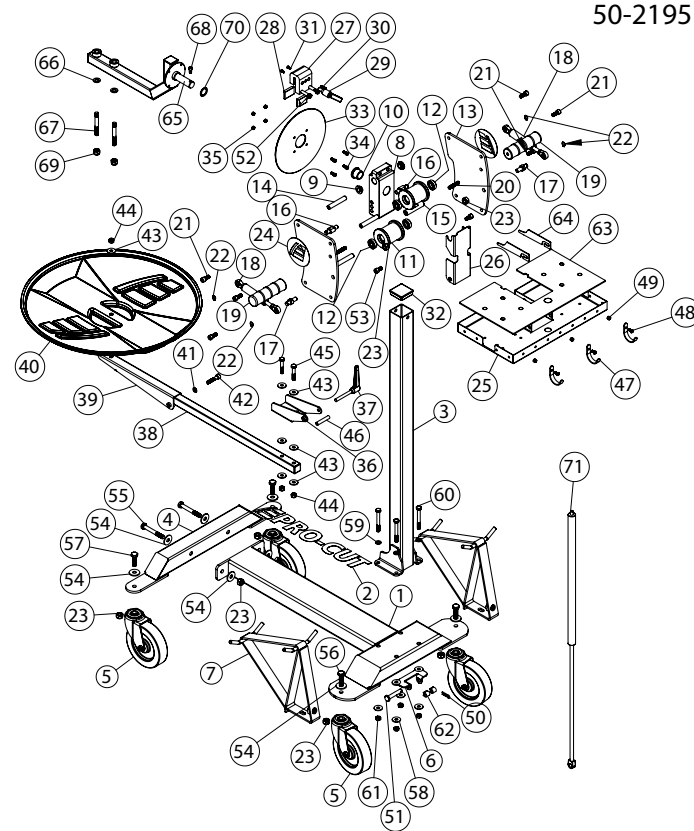

ITEM NO.	PART NUMBER	QTY.
1	50-2047	1
2	50-867	1
3	50-2048	1
4	50-2029	1
5	37-038	4
6	50-2019	1
7	50-2030	2
8	50-2073.1	1
9	37-304	2
10	37-305	2
11	50-2072.1	2
12	37-064	4
13	50-2071	2
14	50-2076	3
15	50-2016	1
16	50-2074	2
17	50-2075	2
18	37-485	2
19	50-1032	2
20	37-721	2
21	35-239	6
22	37-498	4
23	36-001B	8
24	50-968	2
25	50-1456	1
26	50-2078	1
27	50-1061	1
28	50-1062	2
29	37-1065	1
30	35-307	2
31	35-815	2
32	57-818	1
33	50-2034	1
34	35-292	4
35	36-172	4
36	50-2041	1
37	37-484	1
38	50-2042	1
39	50-2043	1
40	50-2044	1
41	37-011	1
42	35-293	1
43	37-110	7
44	35-002	2
45	35-252	2
46	50-2058	1
47	50-2018	3
48	35-278	1
49	36-114	3
50	37-496	1
51	37-046	1
52	35-425	2
53	35-425	2
54	35-114	1
54	37-993	8
55	35-998	2
56	35-343	1
57	35-304	2
58	37-110	4
59	37-003	4
60	35-360	4
61	35-029	4
62	50-2046	2
63	50-2082	1
64	50-2346	2
65	50-2344	1
66	37-108	2
67	35-163	2
68	35-285	1
69	36-001B	1
70	37-097	1
71	37-499	1

ITEM NO.	PART NUMBER	QTY.
1	50-2195-Y	1
2	50-867-BK	1
3	50-2048-Y	1
4	50-2029-Y	1
5	37-038	4
6	50-2019-Y	1
7	50-2030-Y	2
8	50-2073.1	4
9	37-304	2
10	37-305	2
11	50-2072.1	2
12	37-064	4
13	50-2077-Y	4
14	50-2076	4
15	50-2016	1
16	50-2074	2
17	50-2075	2
18	37-485	2
19	50-1032	2
20	37-224	2
21	35-239	6
22	37-158	4
23	35-011B	4
24	50-868-BK	2
25	50-2077-Y	1
26	50-2076-Y	2
27	50-1081	1
28	50-1082	2
29	35-172	2
30	35-307	2
31	35-815	2
32	37-818	2
33	50-2034	1
34	35-292	4
35	35-192	4
36	50-2041-Y	4
37	37-484	1
38	50-2042-Y	1
39	50-2043-Y	1
40	50-2044	1
41	37-011	1
42	35-293	1
43	37-110	7
44	35-092	3
45	35-295	3
46	50-2058	1
47	50-2018-Y	3
48	37-228	3
49	36-114	3
50	37-496	1
51	37-046	2
52	35-425	2
53	35-414	2
54	37-993	3
55	35-998	3
56	35-304	4
57	37-110	4
58	37-003	4
59	35-360	4
60	36-009	2
61	50-2046	2
62	50-2082	1
63	50-2346	2
64	50-2224	1
65	37-108	2
66	35-159	2
67	35-285	1
68	36-001B	2
69	37-097	1
70	37-499	1

50-2195-Y

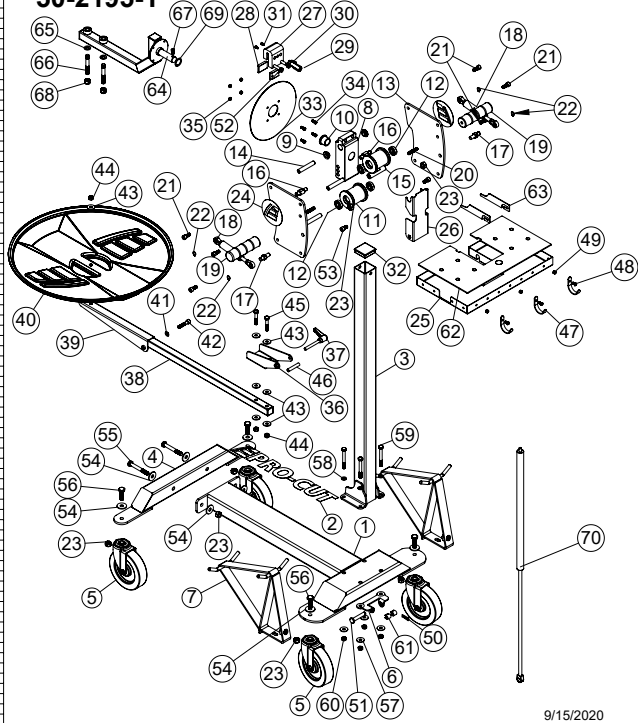

9/15/2020

50-2370

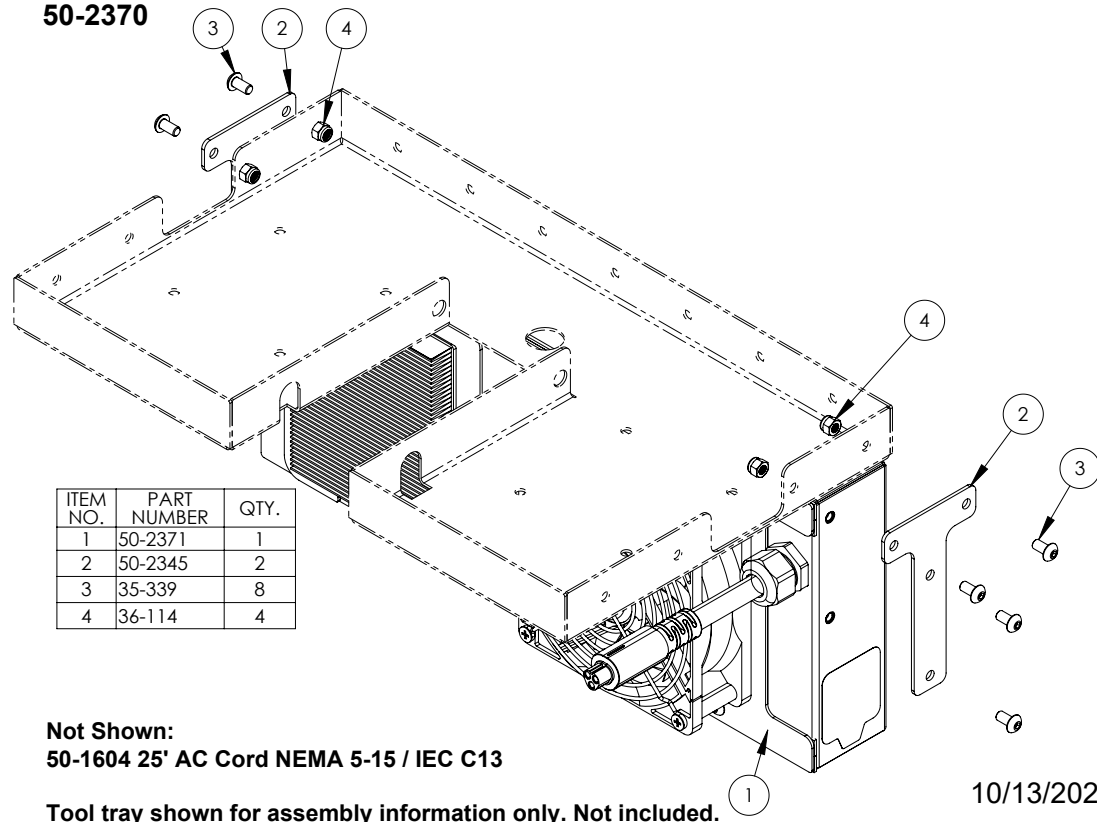

Not Shown:

50-1604 25' AC Cord NEMA 5-15 / IEC C13

Tool tray shown for assembly information only. Not included.

10/13/2022

50-1690

ITEM NO.	PART NUMBER	QTY.
1	50-1651	1
2	37-056	2
3	50-016	1
4	50-1668	1
5	37-057	2
6	35-927	4
7	50-018	1
8	35-926	1
9	50-021	1
10	50-1342	1
11	50-1667	1
12	50-1657	2
13	35-951	2
14	50-1208	3
15	37-1250	3
16	37-077	4
17	50-1665	1
18	35-271	3
19	50-1661	1
20	35-236	2
21	35-015	1
22	35-951	1
23	35-255	4
24	50-070	1

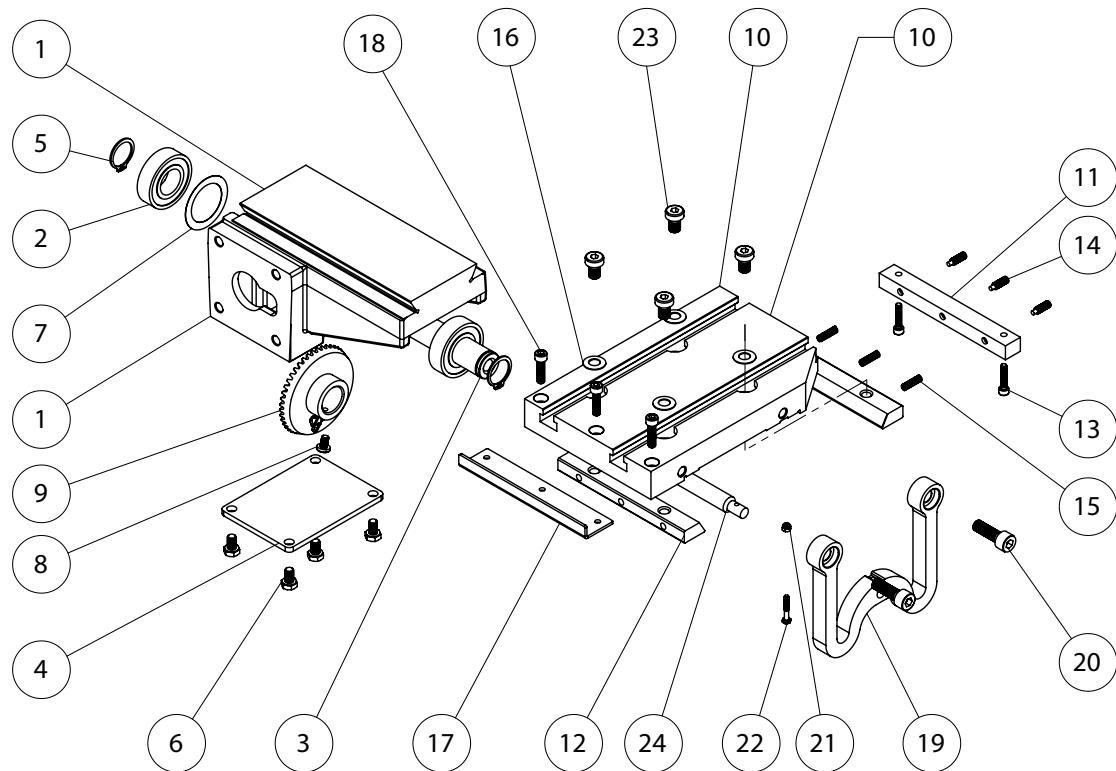

50-2330

ITEM NO.	PART NUMBER	QTY.
1	50-2331	1
2	50-2333	2
3	50-1332	1
4	50-1322	1
5	35-291	4
6	50-1324	1
7	50-1323	1
8	50-1325	1
9	50-1335	1
10	50-1336	1
11	50-1339	2
12	37-1335	1
13	50-252	1
14	37-1331	2
15	50-1343	1
16	35-1331	2
17	35-1335	1
18	50-2338	1
19	37-1332	2
20	35-1332	2
21	37-1308	4
22	37-114	4
23	36-002	2
24	36-010	2

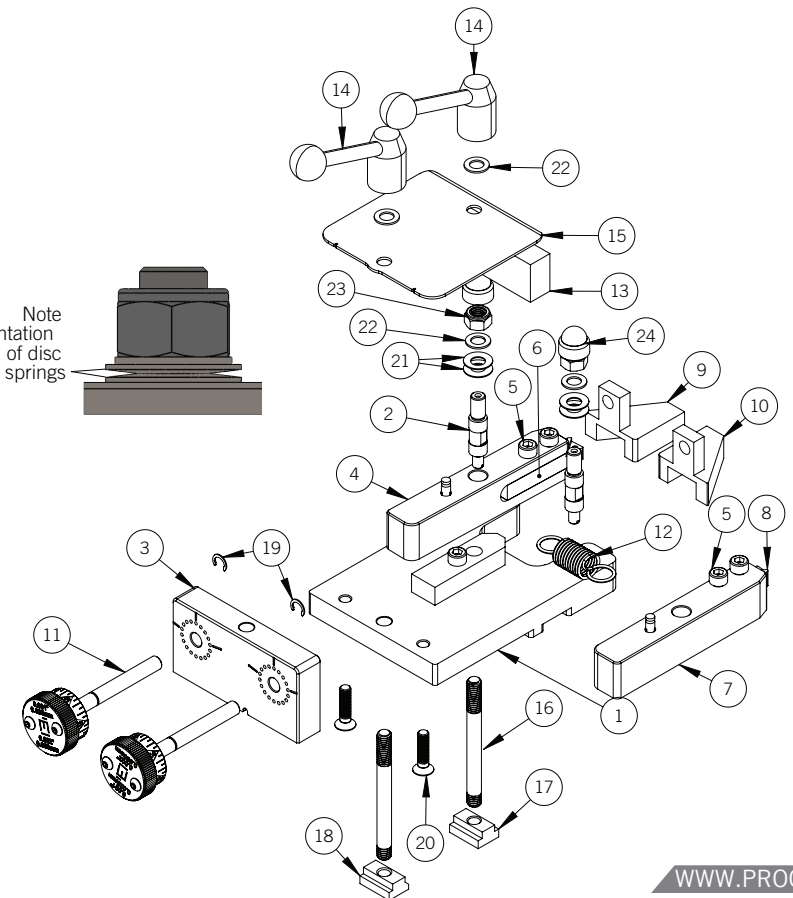
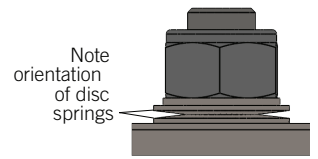

50-2470

ITEM NO.	PART NUMBER	QTY.
1	50-2331	1
2	50-2333	2
3	50-1332	1
4	50-1322	1
5	35-291	4
6	50-1324	1
7	50-1323	1
8	50-1325	1
9	50-1335	1
10	50-1336	1
11	50-1339	2
12	37-1335	1
13	50-252	1
14	37-1331	2
15	50-1343	1
16	35-1331	2
17	35-1335	2
18	37-1332	2
19	35-1332	2
20	37-1308	4
21	37-114	2
22	36-002	2
23	37-114	2
24	36-010	2

Note
orientation
of disc
springs

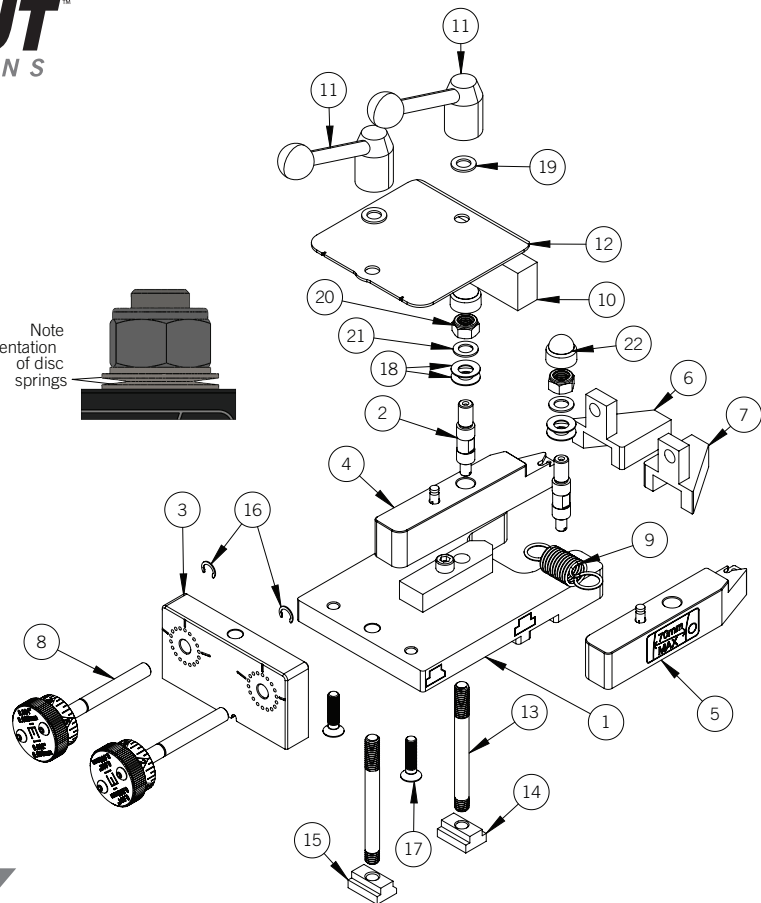

50-2480

ITEM NO.	PART NUMBER	QTY.
1	50-2331	1
2	50-2333	2
3	50-1332	1
4	50-1333	1
5	50-1334	1
6	50-1335	1
7	50-1336	1
8	50-1339	2
9	37-1335	1
10	50-252	1
11	37-1331	2
12	50-1343	1
13	35-1331	2
14	35-1335	1
15	50-2338	1
16	37-1332	2
17	35-1332	2
18	37-1308	4
19	37-114	4
20	36-002	2
21	36-010	2

Note
orientation
of disc
springs

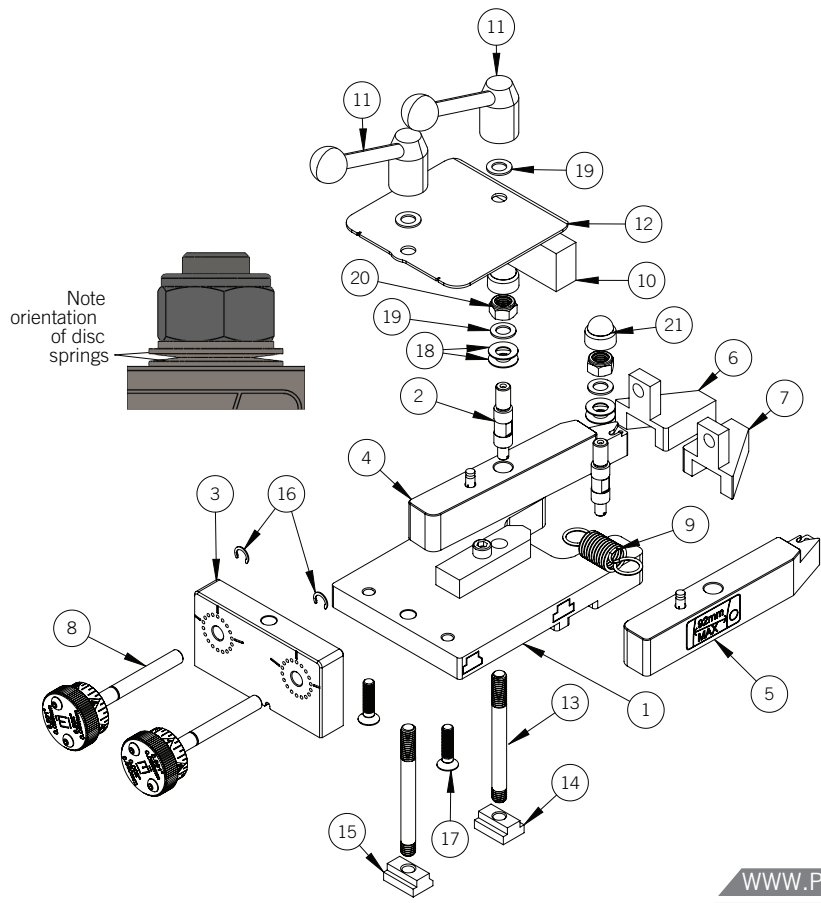

SYSTEM & ERROR MESSAGES

TYPE / DESCRIPTION	DISPLAY TEXT	CAUSE	CORRECTIVE ACTION
Motor Speed Setting	40 to 100	This message is present in the normal sequential message display. Note: the leading character is the middle bar of the 1st character.	None – message is normally active. Rotate right dial to adjust motor speed from 40% to 100%.
Adjust Process Complete	Adj r done r nnnn	'nnnn' is the as-adjusted runout value expected the rotor after cutting.	None. Information alert only. Runout will display either in format 0.0000 if inch units are chosen or 00.00 format if mm units are chosen.
Adjust Timeout Message	LrD r tI nEd r Out	Runout adjustment has taken too long to complete (too many revolutions).	Message is cleared by pressing the motor stop/start button or rotating or pressing the motor speed knob. If you get this message repeatedly there may be issues with your setup (looseness of drawbar is a common cause), or this may indicate a mechanical issue and you should call Pro-Cut for troubleshooting and service. 800-543-6618 (USA) +1-603-298-5200 (Int.)
Motor Start Ignored	E_5toP (fast flash 4x)	E-Stop button is down and user has pressed the motor start/stop button.	None - clears automatically. Release e-stop button by rotating switch cap.
Emergency Stop Active	E_5toP r SAFtY	E-Stop button is down. On lathes equipped with protective screens, this message will also appear if the lower door is not fully closed.	Release e-stop button by rotating switch cap.

SYSTEM & ERROR MESSAGES

TYPE / DESCRIPTION	DISPLAY TEXT	CAUSE	CORRECTIVE ACTION
Service Alert (SA) Message	nR nE r dUE r cRLl r 800- r 543- r 66 18	This message is added to the sequential message display rotation when service alerts are enabled and the cut count exceeds the programmed service alert interval (default 400).	The service alert (SA) can be cleared via the Setup Menu Main->Alert->Reset command. Disabling service alerts or setting the SA Interval to a larger value will also clear the SA condition. This will re-occur each time the service alert counter is reached. It does not prevent use of the lathe.
Free Gift Alert	CRLL r 800- r 543- r 66 18 r For r FREE 9 rFE	This message will display when total runout compensation count is between 100 and 110. After 110 compensations this message will be automatically suppressed.	None. Continue use as normal. Call 800-543-6618 to inquire about the current free gift.
Motor High Current During Start	rotor r LOCH	Motor draws excessive current during startup. Motor stops automatically.	Check that cutting tool is not touching the disc (common if you stop mid-cut and do not move the inserts back out by adjusting depth or feed crank). Press start/stop button to attempt spindle restart.
Thermal Fuse Recovery Time Message	COOL r nnn r 5Ec	For AC motor equipped lathes, this message will appear after the spindle has turned off due to a current overload. 'nnn' will be a number display.	Check if rotor or spindle is jammed (tips left in metal when lathe turned off, for example). Wait for the countdown timer to disappear, and then press the motor start/stop button twice to restart the spindle.

SYSTEM & ERROR MESSAGES

TYPE / DESCRIPTION	DISPLAY TEXT	CAUSE	CORRECTIVE ACTION
Blocking / Low DC Voltage Input	υολε ρ 5Α9	For DC motor equipped lathes, the voltage measured from AC/DC power supply is below 20V. This can occur if the load exceeds the motor capability, or the motor cannot start. It can also indicate a short of the 24V power output.	Ensure adequate AC supply voltage. Decrease cut feed rate. Power cycle lathe. Check for shorts of the 24V power cables and connectors.
High Temperature Fault	εεηρ ρ FFAULTE ρ ΗΙ 9Η	Long duration heavy cutting loads can cause this, as can excessively high ambient temperatures.	None – This fault condition will stop the spindle/feed motors and prevent lathe operation until the internal temperature decreases to < 50 degrees C.
Temperature Fault	εεηρ ρ FFAULTE ρ 50 C	Previously a temperature fault has occurred. Current temp. is below the fault threshold but still too warm to restart spindle. The message text displays current temperature in deg. C.	Wait for the displayed temperature to decrease below 50C. Press start/stop button to clear the latched temperature fault. Press start/stop again to restart spindle.
Excessive Current Draw	Ουερ ρ Αηρ ρ ΛΙ ηη ε	Very high motor load typically caused by excess material removal rate - commonly a thick rust ridge at the outside diameter of the rotor. The motor will stop automatically.	(!) Back inserts out of the material before attempting to re-start the motor. Reduce cutting depth of feed rate if the issue re-occurs. Check that cutting inserts are not damaged or dull. To resume lathe operation the user should press the start/stop button and wait for the normal status message display to re-appear. To restart the motor, press the start/stop button again.

SYSTEM & ERROR MESSAGES

TYPE / DESCRIPTION	DISPLAY TEXT	CAUSE	CORRECTIVE ACTION
Missing Tach Sensor Signal	η0 ρ ΕΑΧ ρ 51 9η	The motor has been enabled, but no tach sensor pulses are being seen by the processor.	Check cable connections to hall sensor mounted next to solenoid coil. Check adjustment flange magnet for damage or or excessive iron chip buildup. Check connection of 15 pin connector between lathe harness and lathe control box.
High RPM Fault	Η 9η ρ ρΡη	Measured RPM over 168 rpm.	Should not be seen. Possible if motor speed and gearbox reduction are mis-matched, such as when a 60 Hz motor is paired with a lathe geared for 50 Hz motors (lower gear reduction).
Cutting Tips Distance	- 1.234	This message is present in the normal sequential message display rotation provided that the lathe is equipped with a thickness measurement electronics (optional). Note: the leading character is the lower bar of the 1st character.	None - this message is displayed if electronic measurement option is installed. If in inch units are selected in the setup menu, the thickness will be displayed as: 1.234; if mm units selected it will display as: 56.78 (note position of decimal point).
Tcm Low/No Battery Alert	εεη ρ Λοβαε	For lathes equipped with a battery-backed disc thickness measuring system, battery is low.	Plug in lathe and leave plugged in to charge this battery. Battery alert will clear automatically when battery has sufficient charge.
Head Calibration Alert	ηΕΑδ ρ εΑΛ	Lathe is equipped with a disc measurement system but any previously set calibration values have been lost (possible due to low Tcm battery)	Use the setup menu to perform a head calibration procedure.

SYSTEM & ERROR MESSAGES

NOTES

TYPE / DESCRIPTION	DISPLAY TEXT	CAUSE	CORRECTIVE ACTION
Tcm General Fault Message	<p>tcm FAULT CALL 1-603 -298- 5200</p>	<p>This is a general fault message indicating one or more of:</p> <ul style="list-style-type: none"> - Tcm internal memory fault. - No microphone signal detected. - No slide sensor or rotary encoders detected. - One or both of the rotary encoders are reporting faults. 	<p>Power cycle lathe and/or replace Tcm.</p>
Cut Detected	<p>cut</p>	<p>Lathe is equipped with a disc thickness measuring and cutting sounds have been detected.</p>	<p>None. Informational alert only. Cut alert can occur when cutting disc or drum. Thickness measurement only available when cutting a disc.</p>
Not Cutting	<p>nocut</p>	<p>Lathe is equipped with a disc thickness measuring and cutting sounds have ceased.</p>	<p>None. Informational alert only. Cut alert can occur when cutting disc or drum.</p>

MAINTENANCE SCHEDULE

DATE MONTH / DAY / YEAR	NOTES	DRO READINGS		
		HOURS	TOTAL DISCS	AVG COMP

MAINTENANCE SCHEDULE

DATE MONTH / DAY / YEAR	NOTES	DRO READINGS		
		HOURS	TOTAL DISCS	AVG COMP



Pro-Cut International, LLC
10 Technology Drive #4
West Lebanon, NH 03784

P. 800.543.6618 / 603.298.5200
F. 603.298.8404
E. info@procutusa.com

Global inquiries please see:
www.procutusa.com

R10/2023

© PRO-CUT INTERNATIONAL, LLC