

**B17**<sup>TM</sup>  
**24V**

*COMBINATION BENCH LATHE*

*TECHNICAL MANUAL*





# **B17**<sup>TM</sup> **24V** *COMBINATION BENCH LATHE TECHNICAL MANUAL*

P · 800.543.6618  
F · 603.298.8404  
info@procutusa.com  
www.procutusa.com

9	Limited Warranty	22	Machining Hub-less and Hubbed Drums
10/11	Lathe Overview / Components	23	Detailed Instructions
12	Brake Lathe Specifications	24	Mounting Hubbed Drums or Rotors
13	List of Standard Accessories	27	Command Module - Machining Mode
14	Acceptance from Carrier	28	Command Module - Set-Up Mode
14	Safety Information	29	Command Module - Statistics Mode
19	Assembly of Lathe	30	Advanced Tips
20	Operations Procedures	31	Diagrams
20	Multi-Speed Settings	46	Maintenance Schedule
21	Set Up for Rotors or Drum Cutting		

**\*NOTE:** When service or replacement parts are required, please contact your local Pro-Cut Representative through either the SuperTech app or through our website: [www.procutusa.com](http://www.procutusa.com)

## OUR MISSION

Pro-Cut International is dedicated to providing our customers with the most advanced, precise, and profitable tools for brake repair. We have worked with, learned from and solved problems for people at all levels of the brake repair business - from the largest auto manufacturers and national service chains to one-bay, one-man operations. It is a business our entire staff lives, eats, and breathes. We welcome you to our table and look forward to working with you to improve your brake service business.

## CONGRATULATIONS!

You have just purchased what we feel is the finest bench brake lathe in the world. Your Pro-Cut B17 is a high quality, precision engineered product designed to give you years of trouble free service. To familiarize yourself with all its features, please take the time to read this owner's manual carefully and store this manual in a safe place for future reference.

Our job is not done until you feel your technician team was trained properly and received all the information needed to operate the B17 efficiently, accurately, and above all, SAFELY.

***Your warranty will begin once you sign off that you are happy with the training.***

For Records and Information:

DATE TRAINED \_\_\_\_\_ PRO-CUT REP NAME \_\_\_\_\_

SERIAL No. \_\_\_\_\_ REP. CONTACT No. \_\_\_\_\_

*FOUND ON BACK OF LATHE*

### ***Limited Warranty***

This warranty extends to the original owner of the equipment. Pro-Cut International warrants this equipment against defects in materials or workmanship as follows.

### ***Labor***

For the period of two (2) years from the original date of purchase, if we determine that the equipment is defective subject to the limitations of this warranty, we will replace it at no charge for labor. Pro-Cut International warrants any such work done against defects in materials or workmanship for the remaining portion of the original warranty period.

### ***Parts***

For the period of two (2) years from the original date of purchase, we will supply, at no charge, new or rebuilt replacement parts in exchange for parts we determine are defective subject to the limitations of this warranty. Pro-Cut International warrants any such replacement parts against defects in materials or workmanship for the remaining portion of the original warranty period.

### ***What Your Warranty Does Not Cover***

This warranty does not apply to damage due directly to misuse, abuse, negligence or lack of maintenance.

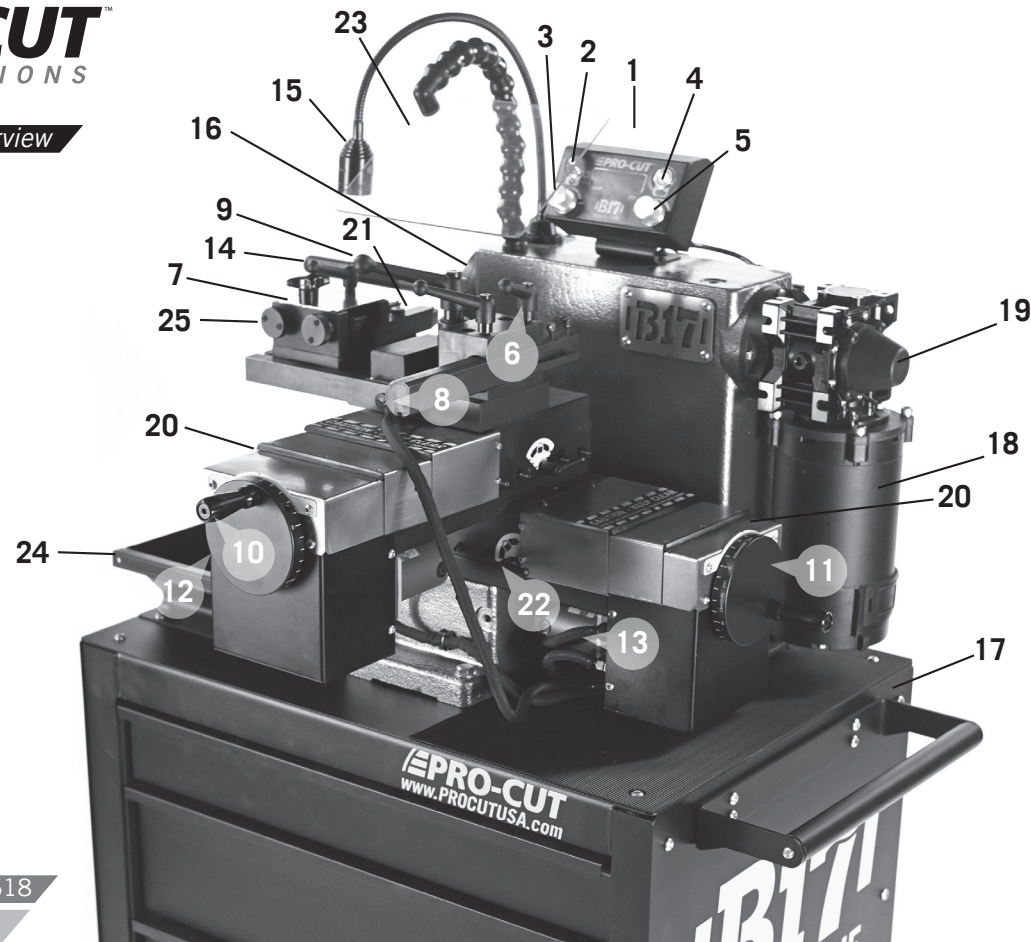

**COMPONENTS**

- |     |   |     |   |
|-----|---|-----|---|
| 1.  | Emergency Stop                              | 14. | 1" Arbor                                      |
| 2.  | Spindle Start/Stop                          | 15. | LED Task Lamp                                 |
| 3.  | Spindle Speed Select Knob                   | 16. | Spindle Ring Lamp ( <i>Hidden From View</i> ) |
| 4.  | Feed Start/Stop                             | 17. | Tool Cabinet Base                             |
| 5.  | Feed Quality Select Knob                    | 18. | Motor   |
| 6.  | Disc/Drum Cutting Plate Lock Lever          | 19. | Draw Bar Cover                                |
| 7.  | Disc Cutting Head                           | 20. | Way Covers                                    |
| 8.  | Drum Boring Bar                             | 21. | Disc Insert holder                            |
| 9.  | Drum Insert Holder                          | 22. | Drum feed lock-out                            |
| 10. | Disc Feed & Drum Depth Crank                | 23. | Chip Guard                                    |
| 11. | Drum Feed & Disc Axial Position Crank       | 24. | Chip Tray                                     |
| 12. | Disc Feed Motor ( <i>Hidden From View</i> ) | 25. | Disc Depth Adjustment Knobs                   |
| 13. | Drum Feed Motor                             |     |   |

**SPECIFICATIONS**

- 90-264VAC 50/60Hz 1ph Input
- Rotor Capacity 4-19.50" [101.6-495mm]
- Maximum width of surface 3.5" [89mm]
- Maximum thickness 2.25" [57mm]
- Maximum drum diameter 26.40" [670mm]
- Friction surface capacity 5.90"
- Maximum Weight on 1" [25.4mm] Arbor: 150 lbs. [68kg]
- Maximum Weight on 1 7/8" Arbor: 300 lbs. [136kg]
- Peak Power 750W
- Spindle Speed RPM 100-140-180
- Feeds per Spindle Revolution
- Disc 0.0016"-0.0039" [0.04-0.10mm] / rev.
- Drum 0.0016"-0.0039" [0.04-0.10mm] / rev.
- Motor: 0.54 HP 400W
- Lathe Weight: 492 lbs. [223 kg]
- Lathe Shipping Weight: 557 lbs. [252 kg]
- Stand Net Weight: 308 lbs. [140 kg]
- Stand Shipping Weight: 391 lbs. [178 kg]

**STANDARD ACCESSORIES INCLUDED WITH THE B17 BENCH LATHE**



- 1 Draw Bar with Hex Nut
- 2 Large Bell Clamp
- 2 Small Bell Clamp
- 4 Centering Cones
- 3 Silencers
- 6 Double Taper Radius Adapters
- 1 Standard 1" Arbor
- 1 Arbor Nut
- 1 1" Spacer
- 1 Set of Alignment Washers
- 1 Spring
- 1 Match Mark Crayon
- 1 Chip brush
- 1 T-8 Tip Screw Wrench
- 1 3mm Gib Screw Wrench
- 1 8/10mm Gib Nut Wrench
- 1 Safety Glasses
- 1 Way Oil w/Brush
- 1 Performance Plus Inserts
- 1 35mm Arbor Nut Wrench

**\*IMAGES NOT TO SCALE**

## ACCEPTANCE FROM TRANSPORTATION CARRIER

Carefully inspect all items received in this shipment. If there is damage or evidence of mishandling in transit, determine the extent of damage and notify the transit company as well as Pro-Cut or your local Pro-Cut rep immediately. Although we are not responsible for damage incurred in transit, we will assist in the preparation and filing of claims.

## SAFETY INFORMATION

This manual has been prepared for the operator and those responsible for the maintenance of the brake lathe. Its purpose, aside from proper maintenance and operations, is to promote safety through the use of accepted practice. READ AND UNDERSTAND THE SAFETY AND OPERATING INSTRUCTIONS COMPLETELY BEFORE OPERATING THE MACHINE.

In order to obtain maximum life expectancy and efficiency from your brake lathe; follow the operating instructions and maintenance manual carefully. The specifications put forth in this manual were in effect at the time of publication. However, owing to Pro-Cut's policy of continuous improvement, changes to the specifications may be made at any time without obligation on the part of Pro-Cut International, LLC.

## SAFETY INSTRUCTIONS

- 1. Read, understand and follow the safety and operating instructions found in this manual.** Know the limitation and hazards associated with operating the machine.
- 2. SPECIAL PRECAUTIONS:** The Pro-Cut B17 brake lathe was designed to machine the portions of the brake drum & disc brake rotor that come in contact with the friction material. When used according to the instructions herein, this lathe will perform satisfactorily within the work piece size range designed for this model. During the machining operation, the work piece rotates. Be especially cautious of rotating spokes and mounted accessories. During machining, material removal may cause a sharp edge to be generated, where a chamfer or radius previously existed. Use care in handling machined parts.
- 3. SECURING THE MACHINE:** The model B17 weighs approximately 470 pounds and must be bolted to either the Pro-Cut Heavy duty bench 50-4400, or a bench capable of supporting the machine, its accessories and work piece.
- 4. GROUNDING THE MACHINE:** In the event of a malfunction or breakdown, grounding provides a path of least resistance for electric current to reduce the risk of electric shock. The lathe is equipped with an electric cord having an equipment-grounding conductor and a grounding plug. The plug must be plugged into a match outlet that is properly installed and grounded in accordance with all local codes and ordinances. Do not modify the plug provided. If the plug will not fit the outlet, have the proper outlet installed by a qualified electrician. If repair or replacement of the electric cord or plug is necessary, do not connect the to a live outlet until repairs are performed. Check with a qualified electrician or service personal if the grounding instructions are not completely understood, or if in doubt as to whether the lathe is properly grounded.
- 5. EXPLOSION RISK:** This machine generates internal sparks. Do not use at less than 18" [0.46m] above grade level, and never use below grade level. Work area should be well ventilated and free of explosive fumes.



## SAFETY INSTRUCTIONS *(continued)*

- 6. USE PROPER EXTENSION CORD:** Use only 3-wire extension cords that have 3-prong grounding plugs and 3-pole receptacles that accept the lathe's plug. Repair or replace damaged or worn cord immediately. Make sure your extension cord is in good condition.
- 7. EYE SAFETY:** Wear an approved safety face shield, goggles, or safety glasses. (Ordinary eyeglasses are not safety glasses and do not provide the degree of protection necessary.)
- 8. RESPIRATORY SAFETY:** If the operation or area is dusty a face or dust mask should be used.
- 9. PERSONAL PROTECTION:** Before operating the machine, remove tie, rings, watches and other jewelry, and roll up sleeves above the elbow. Remove all outer loose clothing and confine long hair. Protective type footwear must be worn. Hearing protectors must be used where noise exceeds the level of exposure allowed in Section 1910.95 of the OSHA Regulations. **DO NOT WEAR GLOVES.**
- 10. DO NOT USE LATHE IN DANGEROUS ENVIRONMENT:** Don't use the lathe in damp or wet locations, or expose the lathe to rain. Keep the work area well lighted.
- 11. WORK AREA:** Keep the floor around the machine clean and free of foreign materials. Pro-Cut recommends the use of anti-skid floor strips where the operator normally stands, and that each machine has its own work area marked off. Make certain that the work area is well lighted and ventilated. Provide for adequate workspace around the machine. The work area should not be readily accessible to anyone except the operator.

## SAFETY INSTRUCTIONS *(continued)*

- 12. DO NOT OVERREACH:** Maintain a balanced stance and keep your body under control at all times.
- 13. HAND SAFETY:** Keep hands away from moving parts when the machine is under power. Never clear chips or debris when the machine is under power and never use your hands to clear the chips. Never use compressed air to clean machine; use only a soft bristle brush or vacuum cleaner.
- 14. MACHINING PREPARATION:** Tighten all appropriate locks before operating the lathe. Be sure work piece is secured. Remove adjusting keys and wrenches. Be sure to check to see that all adjusting wrenches are removed from the lathe before turning the machine on.
- 15. CHECK DAMAGED PARTS:** Before further use of the lathe, a guard or other part that is damaged should be carefully checked to determine if it will operate properly and perform its intended function. Check for alignment of moving parts, binding of moving parts, breakage of parts, mounting, & any other conditions that may affect the lathe's operation. A guard or other part that is damaged should be properly repaired or replaced.
- 16. MAINTAIN TOOLS WITH CARE:** Keep tools sharp and clean for best and safest performance. Follow instructions for lubricating and changing accessories.
- 17. NEVER STAND ON LATHE:** Serious injury could occur if the lathe is tipped or if the cutting tool is unintentionally contacted.

## SAFETY INSTRUCTIONS

18. **MACHINE CAPACITY:** Do not attempt to use the machine for other than passenger car and light truck drums, discs, or for operations for which the machine was not intended.
19. **CARELESS ACTS:** Give the work you are doing your undivided attention!
20. ***Disconnect Electrical Power before performing any service, maintenance, or changing of accessories, adapters, or work pieces on machine.***
21. **JOB COMPLETION:** If the operator leaves the machine area for any reason, the machine should be turned off, and the spindle brought to a complete stop before the operator departs. In addition if the operation is complete, the operator should clean the machine and work area. NEVER CLEAN THE MACHINE WITH THE POWER ON.
22. **REPLACEMENT PARTS:** Use only Pro-Cut replacement parts and accessories, risk of injury may result in accessories other than those recommended are used.
23. **MISUSE:** Do not use the machine for other than its intended use. If used for other purposes, Pro-Cut International, LLC, disclaims any expressed or implied warranty, and holds itself harmless for any injury or loss that may result.

## ASSEMBLY OF BRAKE LATHE

### **SETTING UP BRAKE LATHE FOR FIRST USE**

All machined surfaces are covered with a protective coating before packaging and they must be thoroughly cleaned. The spindle, arbor taper and mounting surface on top of ways must be cleaned and wiped dry. Install the draw bar in the arbor. Insert the draw bar through the spindle. Install the nut on the rear of the draw bar, and tighten. Make sure all inserts, bolts, and set screws are tight.

- Machine must be securely fastened to work bench surface before operating.
- Five mounting holes on the base are provided for this purpose.

### **LUBRICATION**

Lubricate ways by oiling felt wipers on the end of cross slide every week with Pro-Cut 50-376 way oil or equivalent.

For other iron surfaces we recommend high quality rust prevention coating such as CRC brand 3-36 multi-purpose lubricant and corrosion inhibitor.

## B17 MULTI-SPEED BRAKE LATHE OPERATION PROCEDURES OPERATION

The B17 Multi-Speed Lathe has three spindle speeds and variable cross feeds (0.0016-0.0039" [0.04-0.1mm] per revolution) to accommodate a wide range of machining tasks.

Choose spindle speed based on the size of the work piece, slower for larger diameter parts.

The feed adjustment has 11 quality settings, from the finest finish (1) to the coarsest finish (11). Finer finishes use a lower feed rate, and so take longer. The coarsest finish setting, when used with Pro-Cut inserts is designed to give a finish at or about 100 micro-inch / 2.54 micron Ra, the upper roughness limit allowed for many vehicles. The fine setting can achieve surface finishes as low as 45 micro-inch / 1.14 micron Ra. Insert edge quality and rotor condition and material will affect these numbers.

No guarantee can be made for inserts not purchased from Pro-Cut, as insert corner radius, relief angle, material composition and edge preparation can have a strong effect on cutting quality, insert lift, and tendency of the work piece to vibrate. Always use Genuine Pro-Cut 50-778 inserts for best results.

Disc/Drum Diameter	Max Speed	Max Feed	Max Recommended Cut Depth per Side
Up to 12" (305mm)	High	11	.010" (.254mm)
12" to 14" (305-355mm)	Medium	7	.010" (.254mm)
14" to 19.5" (356-495mm)	Low	4	.010" (.254mm)

## SETTING UP FOR ROTOR OR DRUM CUTTING

The tool support plate can be rotated 90 degrees to disc or drum cutting position. The large lever in the center locks and unlocks the support plate. When the plate is in a valid position, you will see the spindle lamp illuminate. The position of this plate determines which axis will feed.

### BASIC STEPS

1. Fit work piece to arbor and clamp in place
2. Choose disc or drum operation by rotating the cutter support plate to the desired location
3. Choose spindle speed (Low, Medium, High)
4. Choose surface quality 1 to 11 (fine to coarse)
5. Set rough tool positions with work piece not rotating
6. Turn on spindle
7. Set depth of cut
8. Turn off spindle
9. Install silencer(s)
10. Turn on spindle
11. Engage feed

## DETAILED INSTRUCTIONS

### **INSPECTION OF BRAKE DRUMS AND ROTORS BEFORE MACHINING**

**IMPORTANT:** The maximum amount of metal removed from the finished work piece should never exceed the manufacturer's machine to/minimum specifications. It is dangerous to operate a vehicle with a drum, rotor or flywheel, which has had more material removed than is allowed. Proper operation cannot be established if these specifications have been exceeded. Pro-Cut International recommends that each work piece be checked for size before mounting on the lathe and after machining.

### **MOUNTING HUB-LESS DRUMS OR ROTORS**

1. Clean and check all surfaces for flatness, especially those that will come in contact with centering cones and/or bell clamps to ensure solid mounting.
2. Cleaning and properly mounting the drum or rotor prior to machining will ensure a minimum of stock removal, better surface finish and optimum braking efficiency.
3. Excessive run out or wobble of the drum or rotor after it has been properly cleaned and mounted on the arbor may indicate severe damage to the drum or rotor. These drums or rotors should not be used for further service.

## DETAILED INSTRUCTIONS *(Continued)*

4. A. Select two proper size bell clamps and slide one on the arbor.  
B. Slide spring on the arbor.  
C. Find the centering cone adapter that fits the center hole of the drum or rotor within the cone range and slide it on the arbor.  
D. Slide the drum or rotor on the arbor and then mount the other bell clamp.  
E. Add necessary spacers (double tapered radius adapters may be used as spacers), alignment washers (make sure they are installed concave to convex), and M24x2 hexagonal nut and tighten securely. Do not jerk or over tighten.
5. A. WRAP RUBBER SILENCER BAND AROUND DRUM, STARTING WITH THE PLAIN END AND MAINTAIN TENSION UNTIL THE CLIP IS SECURED. DO NOT ATTEMPT TO MACHINE DRUMS WITHOUT USING THE SILENCER BAND. Silencer should be nearest open side of drum.  
B. Pro-Cut 50-703 or 50-744 silencer/chip deflector should be used for rotor machining.
6. If arbor appears distorted, check for rust, burrs or chips on cones, drum or rotor, bell clamps, spacers, arbor or other mating surfaces.

## MOUNTING HUBBED DRUMS OR ROTORS

1. Select the double tapered radius adapter that properly fits the inside of the large bearing race. It should sit in the race similar to a bearing and move side to side in all directions easily. If it binds in any direction, this is an indication of an incorrect adapter selection or a damaged bearing race. Correct problem before proceeding.
2. Slide the double tapered radius adapter all the way onto the arbor. If the drum or rotor contacts the lathe, a spacer may be required between the double tapered adapter and lathe.
3. Using the same procedure as in Step 1, select the double tapered radius adapter for the outside race.
4. Install the drum or rotor and position it on the back double tapered radius adapter and then slide the front double tapered radius adapter on the arbor and into the front race.
5. Use adapters or spacers as necessary to space out to the end of the arbor (*See example on Pages 34-35*). Double tapered radius adapters may be used as spacers. Add alignment washers (make sure they are concave to convex) and hex nut or Pro-Cut speed nut, then tighten. Do not shock load, jerk or over tighten.
6. WRAP RUBBER SILENCER BAND AROUND DRUM, STARTING WITH THE PLAIN END AND MAINTAIN TENSION UNTIL THE CLIP IS SECURED. DO NOT ATTEMPT TO MACHINE DRUMS WITHOUT USING THE SILENCER BAND. Silencer should be nearest open side of drum. Pro-Cut disc silencers should also be used for rotor machining.

## MOUNTING HUBBED DRUMS OR ROTORS (*Continued*)

7. If arbor appears distorted, check for dirty or damaged mounting surfaces and/or adapters. Loosen and re-tighten arbor nut as described above in Step 5.

## MACHINING HUB-LESS AND HUBBED DRUMS

1. Position the boring bar so that the 45-degree angle tool bit slot is toward the drum, with the cap screw to the top. BORING BAR EXTENSION SHOULD BE KEPT TO A MINIMUM.
2. For extra small diameter drums, set the boring bar at an angle towards the arbor while extending the boring bar outward from the boring bar holder.
3. Turn on the left spindle speed. Slowly advance the boring bar in the drum and contact the point of the greatest wear.
4. Note the reading on the calibrated hand wheel; back out one full turn and move to the rear of the drum.
5. Set hand wheel to .005" deeper than the noted reading; this should ensure a finished drum in one cut.
6. Select feed speed between 5-8 and engage feed.

**MACHINING HUBLESS AND HUBBED ROTORS**

1. The rotor cutting assembly must be positioned in proper alignment with the rotor. Center the disc rotor between the two tool arms. The tool arms are fed by calibrated knobs at either side of the cutting head.
2. With spindle running, set the tools for depth of cut by loosening the locking lever on top of the cutting head so that the tool arms will move freely when the calibrated knobs are turned.
3. Adjust tool arms to remove the minimum amount required to finish the rotor in one cut.  
**DO NOT MACHINE A ROTOR TO LESS THAN MANUFACTURER'S SPECIFICATIONS.**
4. If surface is scored, locate the deepest score and turn the depth knob until the tool bit bottoms out at the deepest point of the score; counting lines on the knob, back out the tool bit. Repeat on other side. If no score exists, touch rotor with tool bits near outer edge and advance calibrated tool depth knobs until full circle is scratched on. Back out the tool bit 5 lines.
5. Advance the cutting head by hand wheel until the tool bits have cleared the inner edge of the friction face. Advance the micrometer knobs the number of lines you backed off in previous step. Advance both knobs 5 more lines (.005" per side) for standard cutting depth. This will usually be enough to finish the rotor in one cut. Tighten cutting head lock levers and install silencer/deflector.



6. Replacement carbide inserts have three cutting surfaces. When sufficient wear causes an inferior finish, rotate the carbide insert. Always begin on the single dot corner and rotate clockwise to 2 dots, then 3 dots. On \*premium plus cutting tips the first corner is the brand icon.

**DO NOT TURN THESE INSERTS OVER.**

**MACHINING MODE FROM HOME SCREEN**



\*First side shows the Pro-Cut Brand Icon.



Either control knob will function in the same mode.

**Set-up Mode:**

- Long Press > 3 seconds to enter set-up mode.
- Rotate to scroll through options and toggle between choices within an option.
- Short press to select option or drill down to another level.
- Long press to accept changes

**Available Options:**

- Maintenance Alert Reset
- Maintenance Alerts -> On/Off
- Maintenance Alert Interval -> 10-800 Power Cycles (spindle motor on for > 3 seconds)
- Unit of measure -> mm/inches (for machines with optional measuring cutting head)

**Set-up Mode:**

- Short Press < 3 seconds to enter Statistics mode.
- Rotate to scroll through options and toggle between choices between an option.
- Short press to select option or drill down to another level.

**Available Statistics:**

- Spindle motor run time (represented in hours and tenths of an hour)
- Power Cycles (how many times the spindle motor has been turned on for > 3 seconds)
- Disc hours (actual cut time of discs) represented in hours and tenths of an hour
- No. of discs machined (based on 1 pass)
- Drum hours (actual cut time of drums) represented in hours and tenths of an hour
- No. of drums machined (based on 1 pass)
- Module program version numbers (several)



Either control knob will function in the same mode.

ADVANCED TIPS

If machining very large work pieces, you can use the supplied manual slide locks to lock the slide which is not in active use. For example if you are cutting a rotor you could lock the drum slide (and vice-versa). If you are taking moderate cut depths or working with medium or small work pieces this step is likely not necessary. Just remember to unlock the lever before you dismount the work piece as a favor to your future self.

Sharp tools are vital to satisfactory operation.  
When ordering supplies or replacement parts for this machine, always give the model # and serial # of the machine. Use only Genuine Pro-Cut parts.

DRUM INSTALLATION / Recommended Assembly

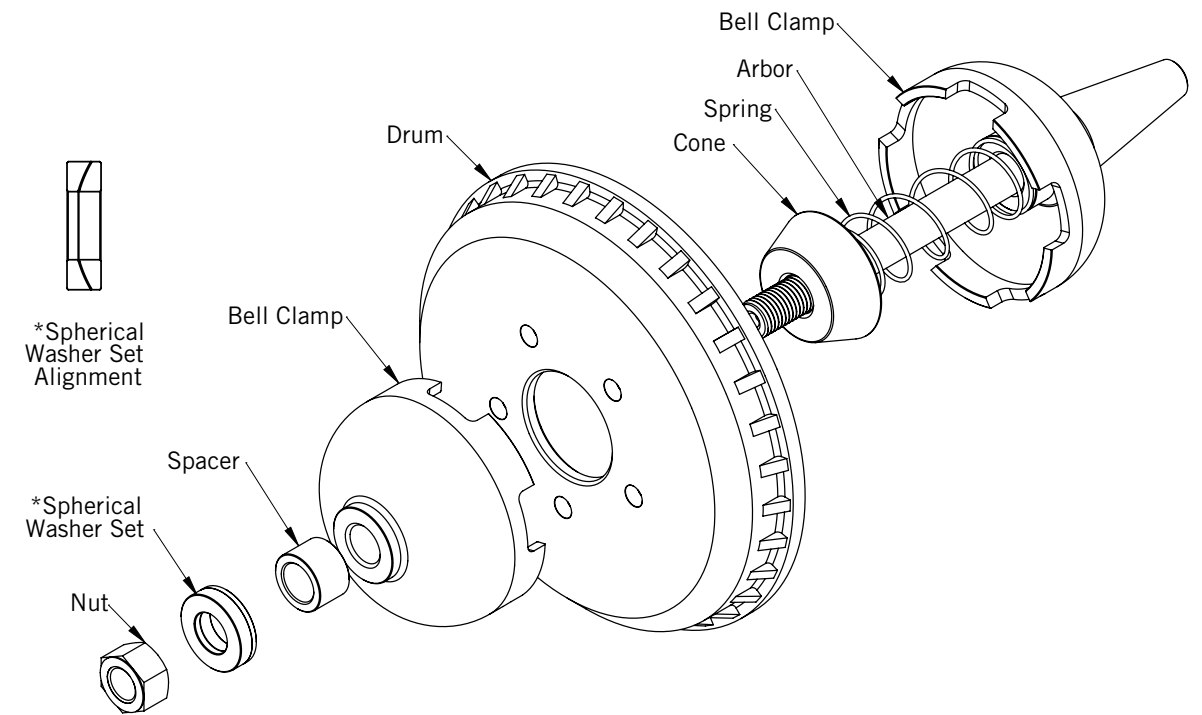



**DISC INSTALLATION / Recommended Assembly**

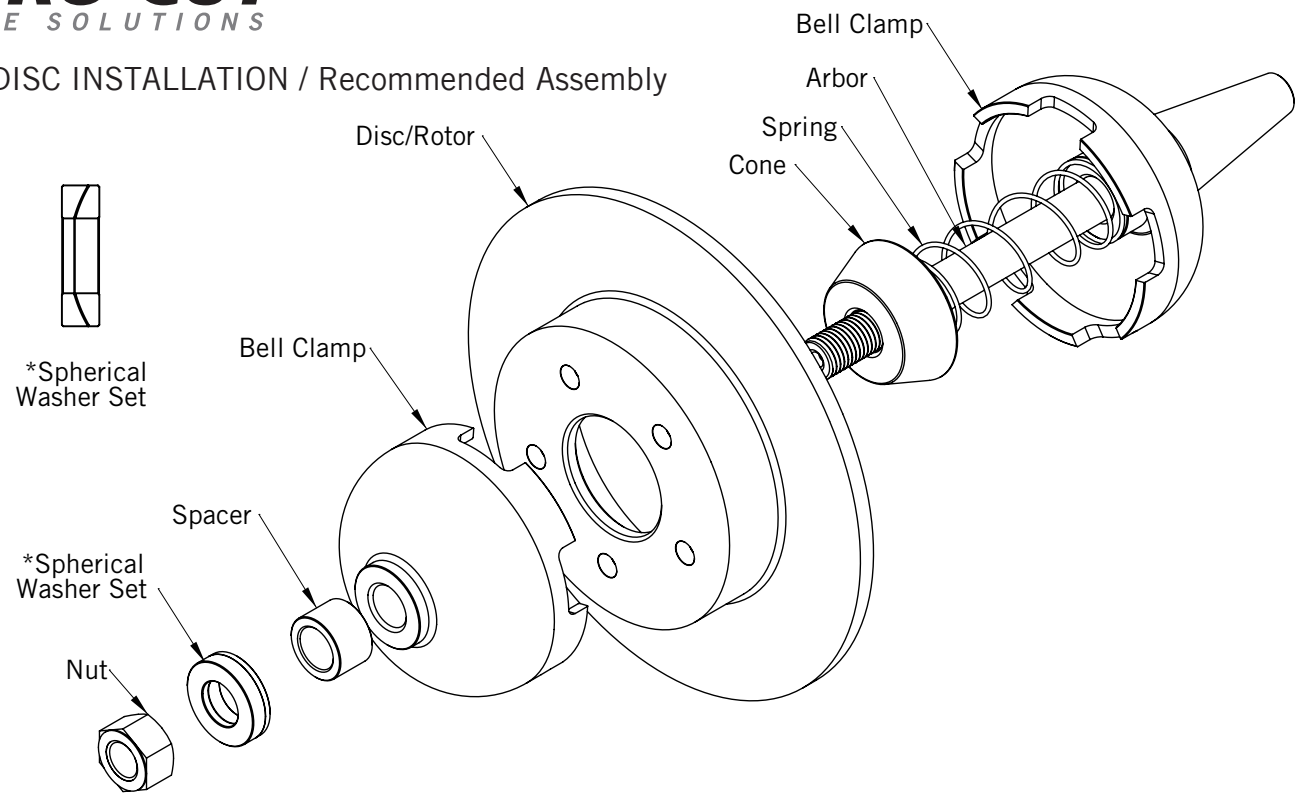

**CABLES(NOT SHOWN)**

PART NUMBER	DESCRIPTION	QTY.
50-4207	Spindle motor power cable	1
50-4208	Rotary sensor cable	1
50-4212	AC Power Cord NEMA 5-15	1
50-4213	Connect 50-2154, 50-2155 and 50-2158.	1
50-4214	Feed motor and Clutch cable	1
50-4218	Gooseneck LED power cable(Outside the E-box)	1
50-4220	Dedicated ground cable	1

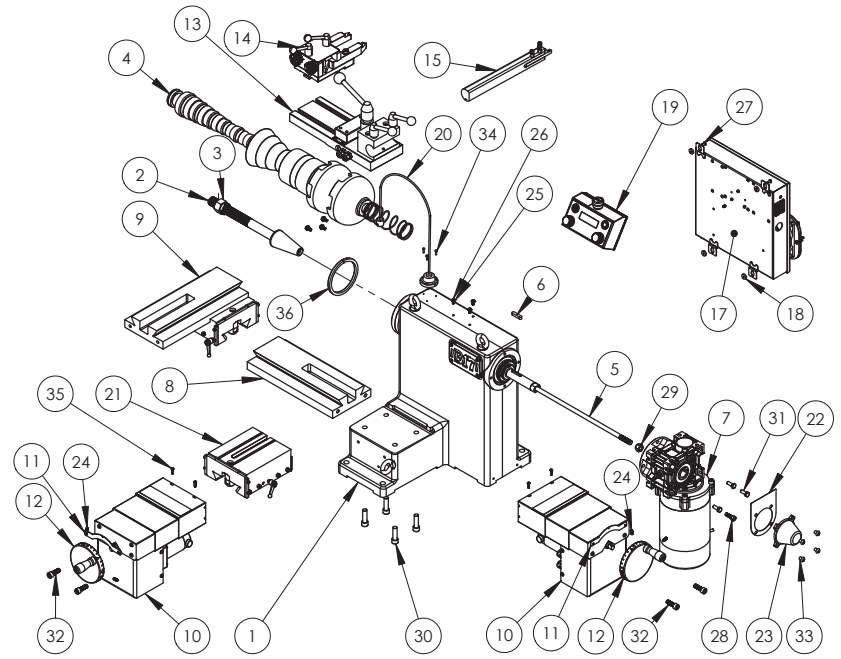

ITEM NO.	PART NUMBER	Mk 2.1/QTY.
1	50-4276	1
2	50-4025	1
3	36-4020	1
4	50-4009	1
5	50-4059	1
6	37-4031	1
7	50-4277	1
8	50-4054	1
9	50-4275	1
10	50-4345	2
11	50-4099	2
12	50-4096	2
13	50-4063	1
14	50-1330	1
15	50-4279	1
16	50-4360	1
17	50-4079	4
18	50-4170	1
19	37-4046	1
20	50-4274	1
21	50-4142	1
22	50-4190	1
23	35-4004	4
24	37-4063	3
25	35-278	3
26	35-339	4
27	35-4006	1
28	36-4005	1
29	35-4002	4
30	35-4003	3
31	35-4027	4
32	35-4030	4
33	35-4031	3
34	35-4058	4
35	37-4047.1	1

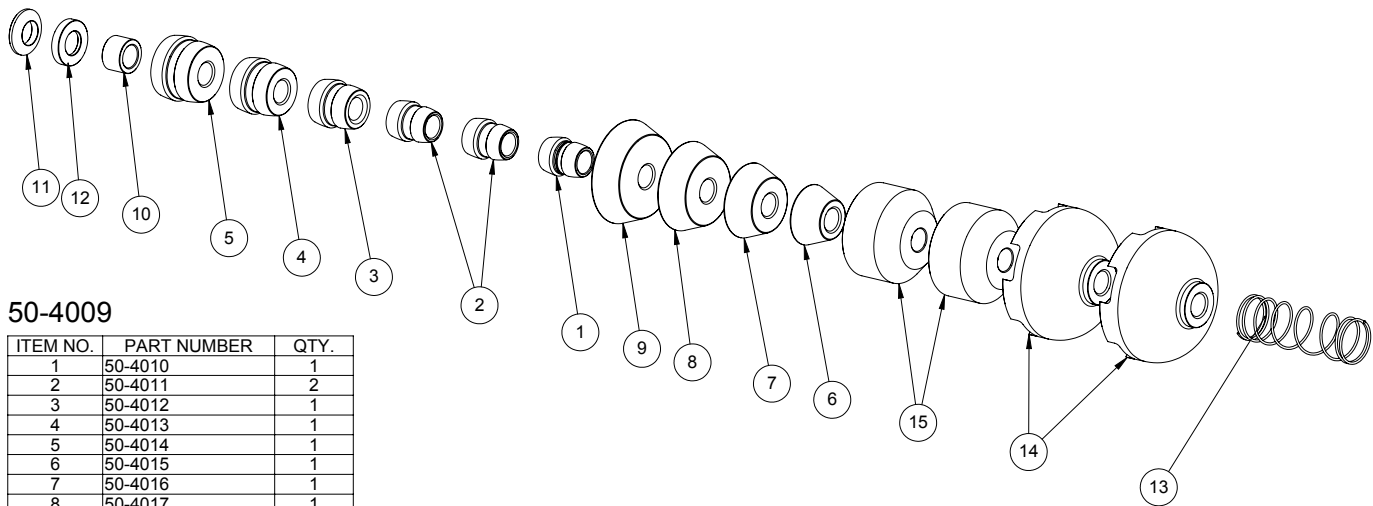

**50-4009**

ITEM NO.	PART NUMBER	QTY.
1	50-4010	1
2	50-4011	2
3	50-4012	1
4	50-4013	1
5	50-4014	1
6	50-4015	1
7	50-4016	1
8	50-4017	1
9	50-4035	1
10	50-4018	1
11	50-4019	1
12	50-4020	1
13	50-4021	1
14	50-4022	2
15	50-4023	2

**50-1330**

ITEM NO.	PART NUMBER	QTY.
1	50-1331	1
2	37-1333	2
3	50-1332	1
4	50-1333	1
5	50-1334	1
6	50-1335	1
7	50-1336	1
8	50-1339	2
9	37-1335	1
10	50-252	1
11	37-1331	2
12	50-1343	1
13	35-1331	2
14	35-1335	2
15	37-1332	2
16	35-1332	2
17	35-1330	2
18	37-1330	2
19	37-114	2

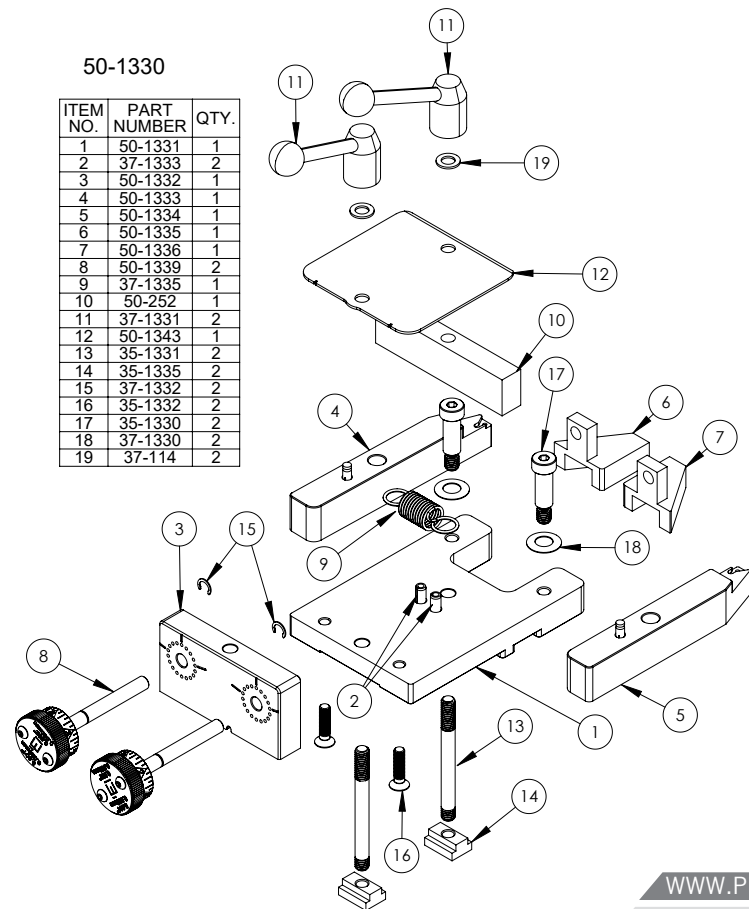

50-4063

ITEM NO.	PART NUMBER	QTY.
1	50-4064	1
2	35-4011	2
3	37-4026	2
4	35-4022	2
5	35-4021	4
6	50-4006	1
7	37-4032	2
8	37-4001	1
9	35-4000	2
10	50-4007	1
11	50-4061	1
12	37-4033	1
13	50-4180	1
14	37-4051	3

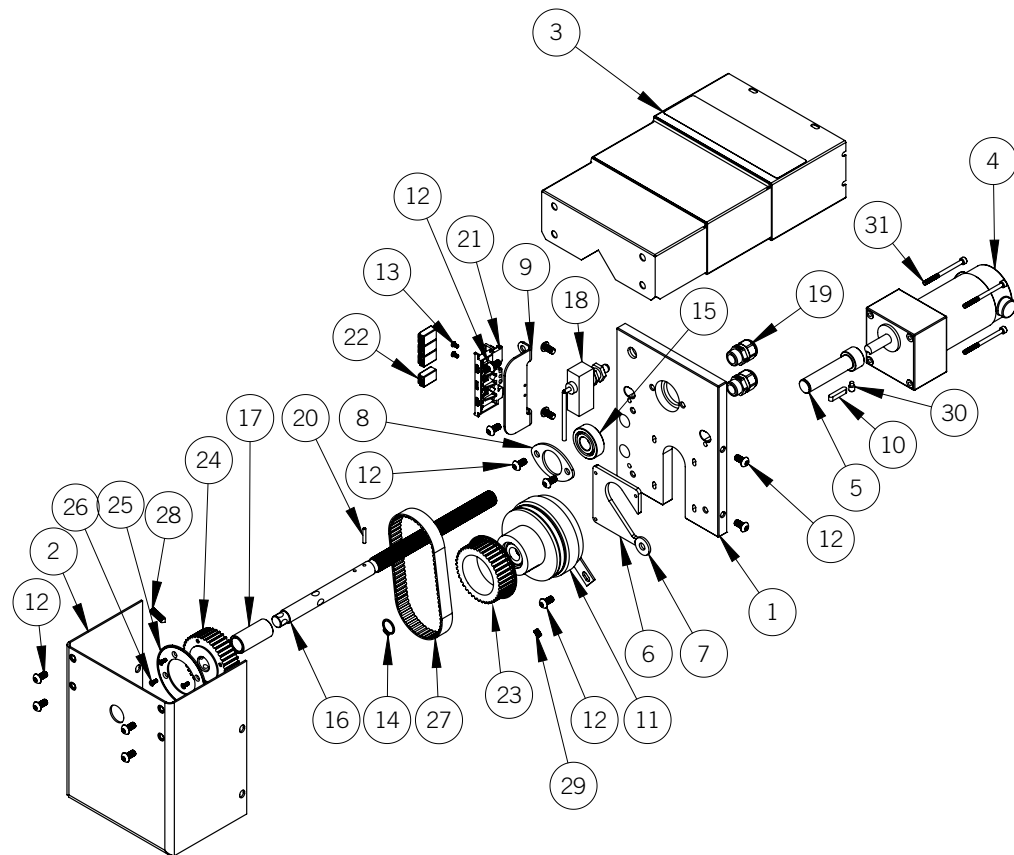
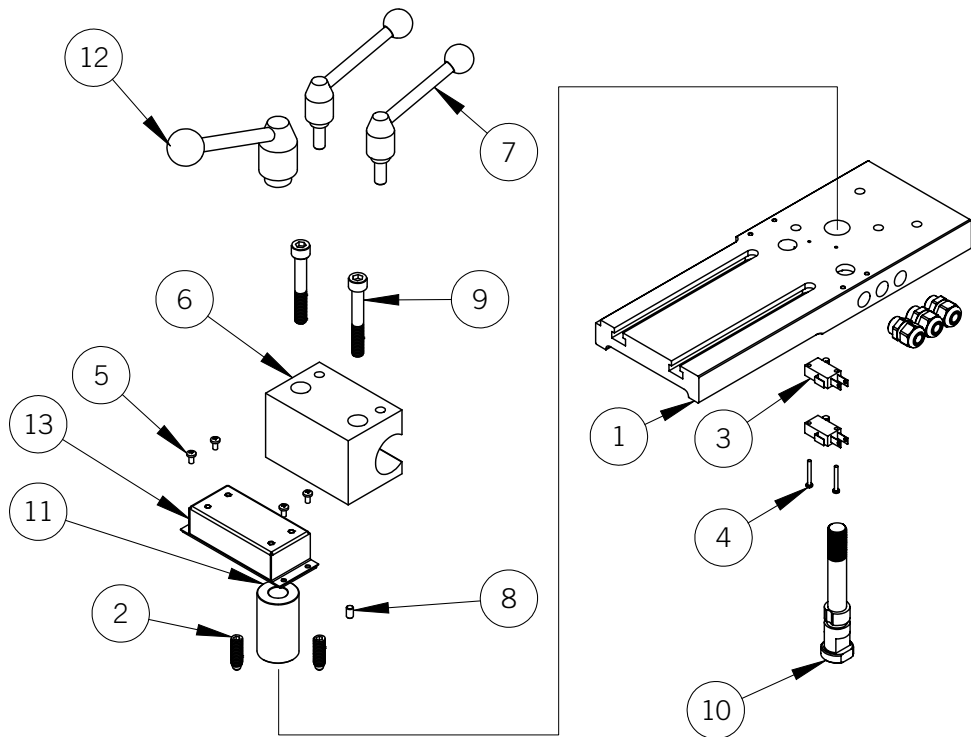

50-4345

BOM Table		
ITEM NO.	PART NUMBER	50-4345/QTY.
1	50-4350	1
2	50-4355	1
3	50-4027	1
4	37-4022	1
5	50-4049	1
6	50-4351	1
7	50-4354	1
8	50-4352	1
9	50-4353	1
10	37-4018	1
11	37-4016	1
12	35-335	13
13	37-4015	1
14	37-4014	1
15	50-4050	1
16	50-4078	1
17	37-4020	1
18	37-4051	2
19	37-4019	1
20	37-4060	1
21	37-4052	4
22	37-4074	1
23	50-4300	1
24	50-4301.1	1
25	50-4302	1
26	35-955	4
27	37-4077	1
28	35-954	2
29	35-953	1
30	35-4048	1
31	35-341	2
32	35-342	4

50-4360

ITEM NO.	PART NUMBER	QTY.
1	50-4313	1
2	35-339	4
3	50-2154	1
4	50-2157	1
5	50-2159	1
6	37-4050	1
7	37-4034	1
8	50-4325	1
9	35-4033	12
10	50-4194	2

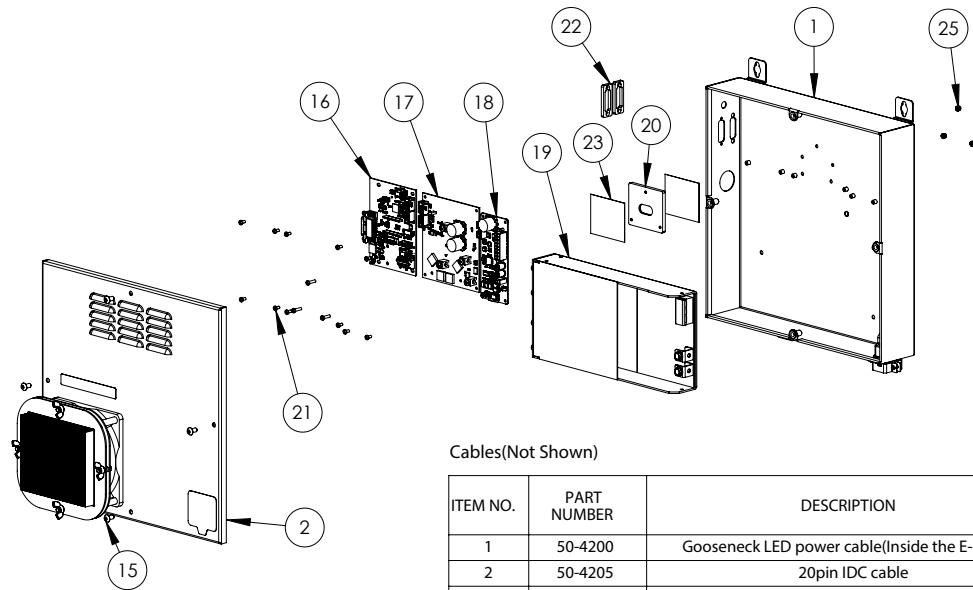

Cables(Not Shown)

ITEM NO.	PART NUMBER	DESCRIPTION	QTY.
1	50-4200	Gooseneck LED power cable(Inside the E-box)	1
2	50-4205	20pin IDC cable	1
3	50-4206	24V power input	1
4	50-4209	50-2159 power cable	1
5	50-4210	10pin IDC cable	1
6	50-4211	50-2159 outputs to DB15	1

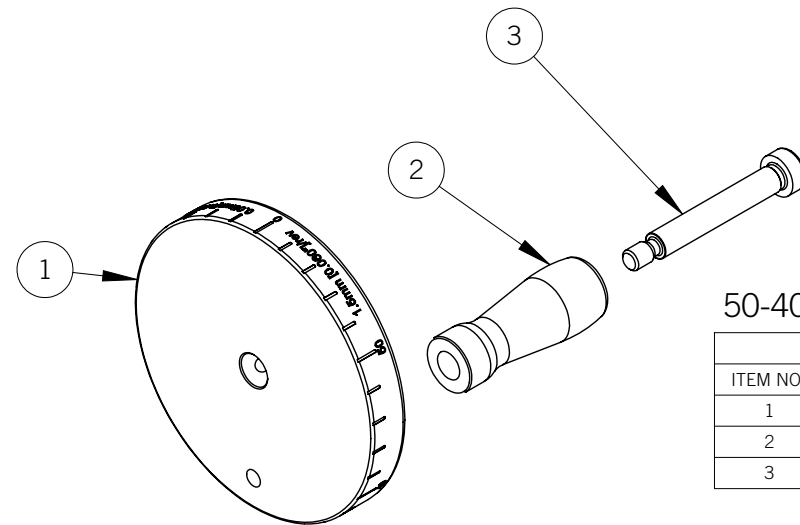

50-4096

BOM Table		
ITEM NO.	PART NUMBER	QTY.
1	50-4097	1
2	50-4098	1
3	35-4032	1

50-4170

Cables(Not shown)

ITEM NO.	PART NUMBER	QTY.
1	50-4171	1
2	50-2155	1
3	35-801	4
4	50-2145	2
5	50-2241	2
6	35-4041	2
7	35-4033	6
8	37-4047.2	1
9	50-4174	1
10	50-4176	1
11	50-4178	2
12	50-4179	2
13	37-4063	4

item No.	Part Number	Description	QTY.
1	50-4201	Rotary control cable	1
2	50-4204	10pin to DB15	1
3	50-4221	Spindle start/stop button and cable	1
4	50-4222	Feed start/stop button and cable	1
5	50-4217	E-stop button and cable	1

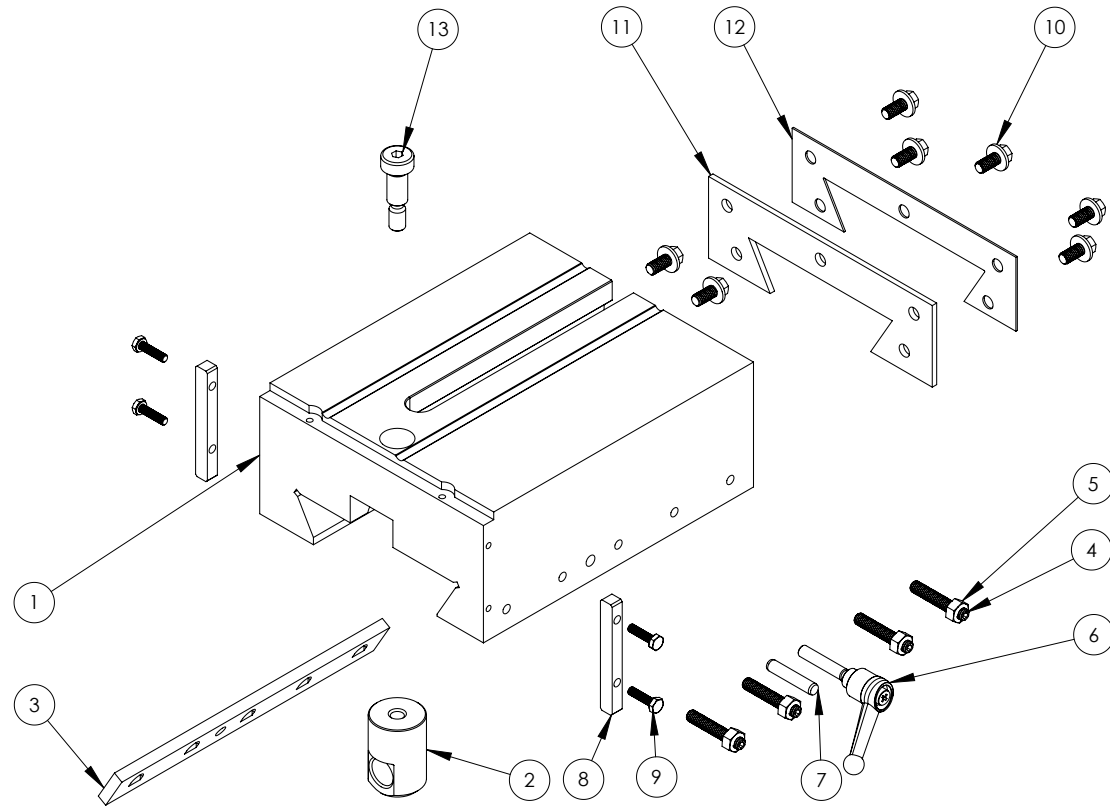
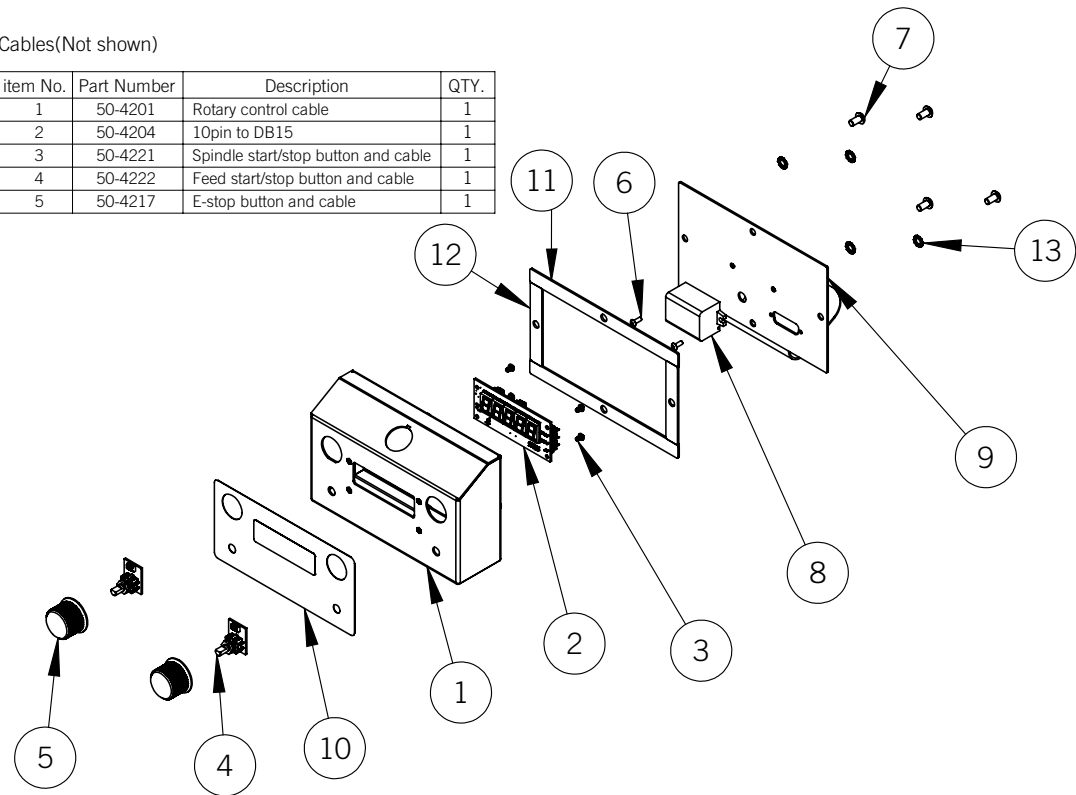

50-4274

ITEM NO.	PART NUMBER	QTY.
1	50-4051	1
2	50-4052	1
3	50-4053	1
4	35-4005	4
5	36-4003	4
6	37-4061	1
7	37-4028	1
8	50-4032	2
9	35-4056	4
10	35-4001	7
11	50-4026	1
12	50-4043	1
13	35-4028	1

50-4275

ITEM NO.	PART NUMBER	QTY.
1	50-4055	1
2	50-4032	2
3	35-4056	4
4	50-4053	1
5	35-4028	1
6	50-4052	1
7	37-4061	1
8	36-4003	4
9	35-4005	4
10	37-4028	1
11	50-4026	1
12	35-4001	5
13	50-4043	1

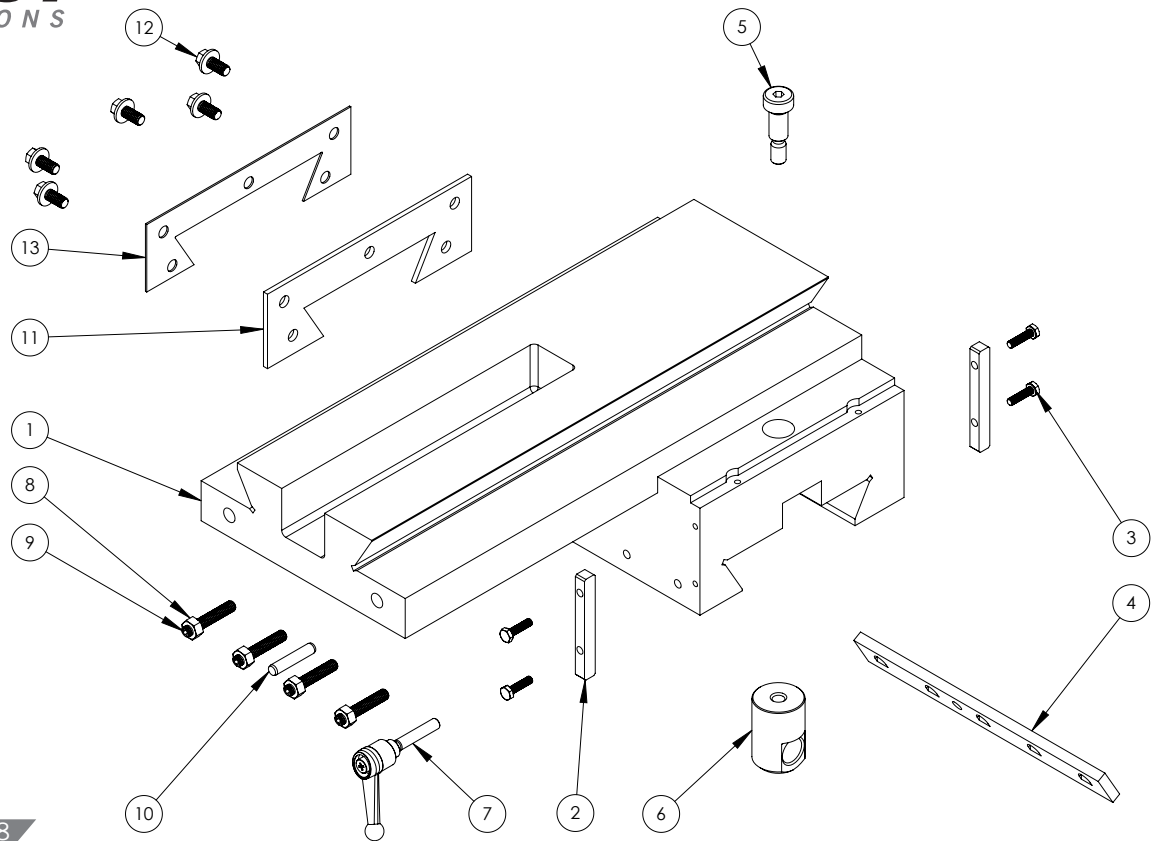

50-4276

ITEM NO.	PART NUMBER	QTY.
1	37-4009	1
2	50-4057	1
3	37-4007	1
4	37-4003	1
5	37-4004	1
6	50-4056	1
7	37-4010	1
8	37-4005	1
9	37-4006	1
10	37-4011	1
11	50-4058	1
12	37-4030	1
13	35-4004	3
14	50-4070	1
15	35-4001	3
16	50-4060	1
17	37-4008	1
18	35-4015	3
19	50-4137	1
20	50-4800	1

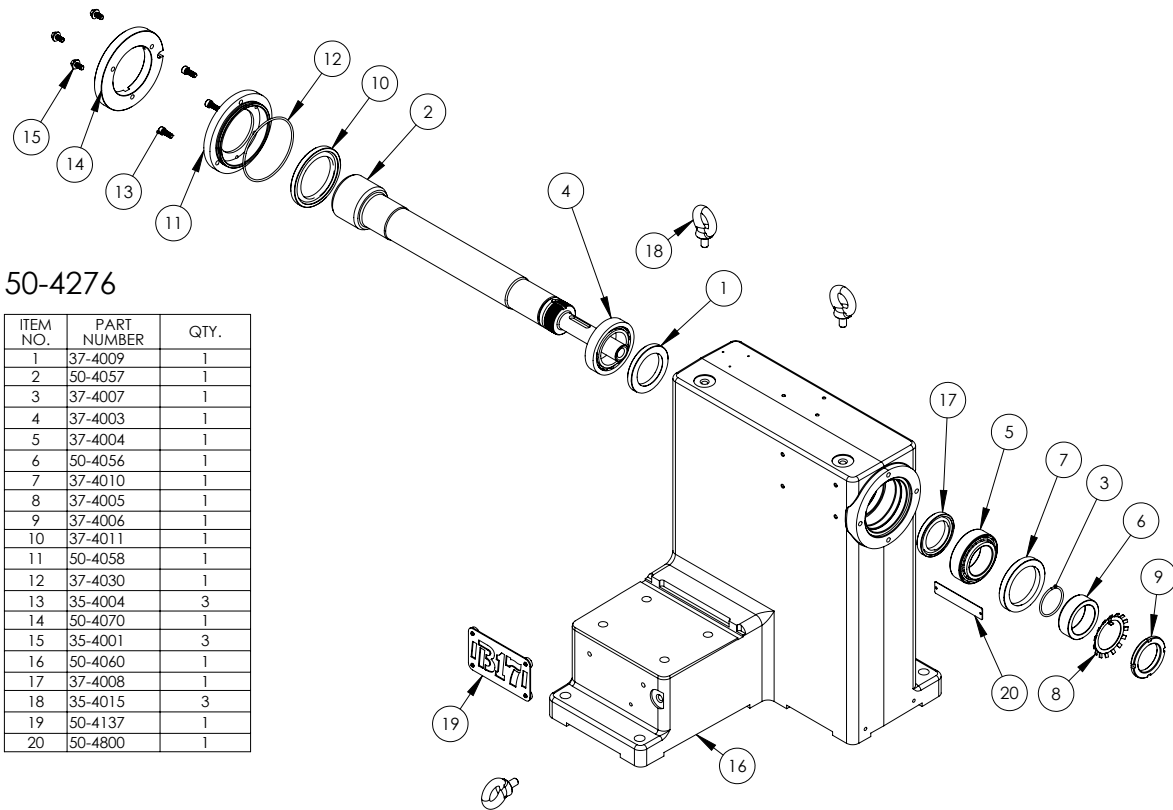

50-4277

ITEM NO.	PART NUMBER	QTY.
1	37-4024	1
2	50-4090	1
3	35-4006	4
4	37-4045	1
5	50-4024	1
6	50-4139	1
7	35-4026	4
8	36-4017	4
10	35-4057	4
11	37-4656	1
12	37-4655	1

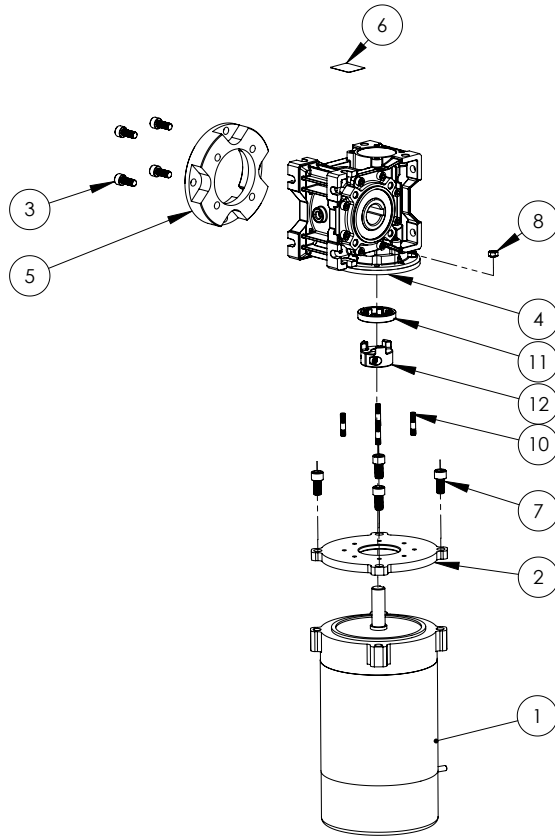

50-4279

ITEM NO.	PART NUMBER	Small Drum Capable/QTY.
1	50-4005	1
2	50-4008	1
3	35-4020	3
4	50-4106	1

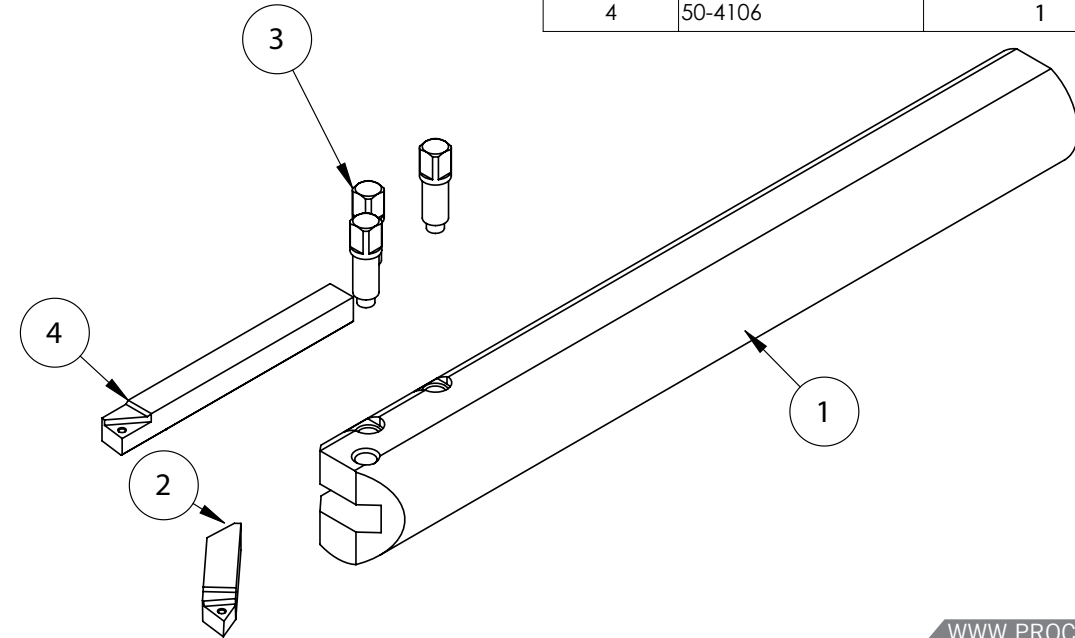

**SYSTEM ERROR MESSAGES**

TYPE / DESCRIPTION	DISPLAY TEXT	CAUSE	CORRECTIVE ACTION
Blocking / Low DC Voltage Input	υολε ρ 5R9	Voltage measured from AC/DC power supply is below 20V. This can occur if the load exceeds the motor capability, or the motor cannot start.	Ensure adequate AC supply voltage. Decrease cut feed rate. Power cycle lathe.
Blocking / Emergency Stop Active	Ε_5εDP ρ 5RFEY	E-Stop button is down. On lathes equipped with protective screens, this message will also appear if the lower door is not fully closed.	Release e-stop button by rotating switch cap. IF dust enclosure w/safety switches is installed, ensure side door is fully closed.
Blocking / High Temperature Fault	εετP ρ FRAULε ρ HIGH	Long duration heavy cutting loads can cause this, as can excessively high ambient temperatures.	None – This fault condition will stop the spindle/feed motors and prevent lathe operation until the internal temperature decreases.
Blocking / Excessive Current Draw	OUER ρ RτP ρ LIτILε	Very high motor load typically caused by excess material removal rate.	This is a “latching” fault condition. On initial detection the spindle/feed motors are stopped. Once the motors are stopped, the over-current condition goes away but the error message is “latched” on (ie does not clear automatically). To resume lathe operation the user should press the start/stop button and wait for the normal status message display to re-appear. To restart the spindle motor, press the start/stop button again.
Blocking / Feed PCB Temp. Fault	FEEd ρ εετP	Feed motor is over temperature limit.	Reduce cutting depth or feed rate. Check that cutting inserts are not damaged or dull.

**SYSTEM ERROR MESSAGES**

TYPE / DESCRIPTION	DISPLAY TEXT	CAUSE	CORRECTIVE ACTION
Blocking / Drum Feed Motor Fault	drUM ρ FRAULε	Feed Control PCB Drum feed motor drive IC fault.	Power cycle lathe. If condition persists call for service.
Blocking / Disc Feed Motor Fault	dISC ρ FRAULε	Feed Control PCB Disc feed motor drive IC fault.	Power cycle lathe. If condition persists call for service.
Blocking / Drum End of travel	drUM ρ Eoε	Axial (drum) feed at farthest limit of travel. Only active in drum cutting mode.	Use feed crank to move the drum slide away from the end of travel.
Blocking / Disc End of Travel	dISC ρ Eoε	Radial (disc) feed at farthest limit of travel. Only active in disc cutting mode.	Use feed crank to move the disc slide away from the end of travel.
Blocking / Feed Motor Low Voltage	FEEd ρ υολεS	DC Input voltage measured at Feed Control PCB is below 20V.	Power cycle lathe. Make sure AC supply has sufficient current capability. Reduce cutting depth or feed rate during cutting.
Blocking / Feed Motor Hi Current	FEEd ρ ττοεor ρ RτPS ρ SEE ρ λoεH ρ λEuER	Current used by active feed motor exceeds 2 Amps.	Check that feed mechanism manual locking lever is not locked. Check that the gib screws are not overly tight. Reduce feed rate during cutting. Power cycle lathe.
Blocking / Feed Clutch Hi Current	FEEd ρ εευεεH ρ RτPS	Feed clutch current exceeds 2A.	Check for wiring faults and shorts on the feed clutch wiring, especially for clutch supply wires shorting to adjacent metal parts. Power cycle lathe.



### SYSTEM ERROR MESSAGES

TYPE / DESCRIPTION	DISPLAY TEXT	CAUSE	CORRECTIVE ACTION
Blocking / Spindle Motor High Current During Start	rotor / lock	Spindle motor draws excessive current during startup. Spindle motor stops automatically.	Check cutting tool is not touching drum/disc (common if you stop mid-cut & do not move inserts back out by adjusting depth/feed crank). Press start/stop button for spindle restart.
Exception / Service Alert (SA) Message	Service Alert / Clear / 800- / 543- / 66 18	This message is added to the sequential message display rotation when service alerts are enabled and the sum of disc cuts plus drum cuts exceeds the programmed service alert interval (default 400).	The service alert can be cleared via the Setup Menu Main->Alert->Reset command. Disabling service alerts or setting the SAInterval to a larger value will also clear the SA condition. This will re-occur each time the service alert counter is reached. It does not prevent use of the lathe.
Exception / Feed Speed Setting	- h 19h	This message is present in the normal sequential message display. Note: the leading character is the top bar of the 1st character.	None – Message is normally active. Rotate left dial to adjust spindle RPM Low (100 RPM), Med(ium) (140 RPM), High (180 RPM).
Exception / Spindle Speed Setting	- 11	This message is present in the normal sequential message display. Note: the leading character is the middle bar of the 1st character.	None – Message is normally active. Rotate right dial to adjust feed rate from 1 (slowest) to 11 (fastest). Why 11? Because sometimes you just need to give it 110%.
Exception / Cutting Tips Distance	- 1.234	This message is present in the normal sequential message display rotation provided that the lathe is equipped with a thickness measurement electronics (optional). Note: the leading character is the lower bar of the 1st character.	None - Message is displayed if electronic measurement option is installed. If inch units are selected in the setup menu, the thickness will be displayed as: 1.234; if mm units selected it will display as: 56.78 (note pos. of dec. pt.).

### SYSTEM ERROR MESSAGES

TYPE / DESCRIPTION	DISPLAY TEXT	CAUSE	CORRECTIVE ACTION
Exception / Tcm Low/No Battery Alert	TCM / LowBat	For lathes equipped with a batter-backed disc thickness measuring system, battery is low.	Plug in lathe and leave plugged in to charge this battery. Battery alert will clear automatically when battery has sufficient charge. Press start/stop button to attempt spindle restart.
Exception / Head Calibration Alert	HEAD / CAL	Lathe is equipped with a disc measurement system but any previously set calibration values have been lost (possible due to low Tcm battery).	Use the setup menu to perform a head calibration procedure.
Exception / Tcm General Fault Message	TCM / FAULT / CAL / 1-603 / -298- / 5200	This is a general fault message indicating one or more of: - Tcm internal memory fault. - No microphone signal detected. - No slide sensor or rotary encoders detected. - One or both of the rotary encoders are reporting faults.	Power cycle lathe and/or replace Tcm.
Exception / Temperature Fault	TEMP / FAULT / 50 C	Previously a temperature fault has occurred. Current temp. is below the fault threshold but still too warm to restart spindle. The message text displays current temperature in deg. C.	Wait for the displayed temperature to decrease below 50C, press start/stop button to clear the latched temperature fault. Press start/stop again to restart spindle.
Exception / Upper Protective Shield Warning	Top / door	Some dust enclosures are equipped with safety switches that monitor the doors around the cutting tool area. This message indicates that the upper door is not in a safe position. Note: This is a status warning only and does not prevent operation of the spindle.	Check to ensure that the upper safety barrier is fully closed.

**SYSTEM ERROR MESSAGES**

TYPE / DESCRIPTION	DISPLAY TEXT	CAUSE	CORRECTIVE ACTION
Exception / Side Protective Door Warning	S_dE r' door (repeats 3x)	Operator has attempted to start feed motor while side protective door is not closed.	Close side protective door then press feed start/stop button.
Exception / Spindle Power Limiting	P_L_Lt	For lathes equipped with Rev 1 spindle power control boards, if the measured motor current exceeds 30A, the spindle power level is automatically reduced by about 8%. If this has occurred, and the operator attempts to manual increase the spindle speed during a cut, this warning is displayed and the attempted spindle adjustment is ignored.	Reduce cutting depth or feed rate. Check that cutting inserts are not damaged or dull.
Exception / Cut Detected	cUt	Lathe is equipped with a disc thickness measuring and cutting sounds have been detected.	None. Informational alert only. Cut alert can occur when cutting disc or drum. Thickness measurement only available when cutting a disc.
Exception / Not Cuttin	nocUt	Lathe is equipped with a disc thickness measuring and cutting sounds have ceased.	None. Informational alert only. Cut alert can occur when cutting disc or drum.
Exception / Spindle Start Ignored	E_5toP (fast flash 4x)	E-Stop button is locked in the down/active position and user has pressed the spindle or feed start/stop button.	None - clears automatically. Release e-stop button by rotating switch cap.

**NOTES**

**MAINTENANCE SCHEDULE**

DATE	NOTES	DRO READINGS		
		HOURS	TOTAL DISCS	TOTAL DRUMS
MONTH / DAY / YEAR				

**MAINTENANCE SCHEDULE**

DATE	NOTES	DRO READINGS		
		HOURS	TOTAL DISCS	TOTAL DRUMS
MONTH / DAY / YEAR				



**Pro-Cut International, LLC**  
10 Technology Drive #4  
West Lebanon, NH 03784

**P.** 800.543.6618 / 603.298.5200  
**F.** 603.298.8404  
**E.** [info@procutusa.com](mailto:info@procutusa.com)

Global inquiries please see:  
**[www.procutusa.com](http://www.procutusa.com)**

R7/2023

© PRO-CUT INTERNATIONAL, LLC